

Thank you for purchasing the **MODWAY BED !**

Before you start, here is some helpful advice:

1. We suggest you spend a short time reading through this leaflet and then follow the simple step by step instructions.
2. Owing to the size and weight of the bed, we recommend that it is assembled by two adults, on a carpeted or padded area, in the room that it is intended for. Approx assembly time: 20 minutes.
3. Please do not use any tools other than those provided or recommended in these instructions.
4. Please do not throw away any of the packaging or the instruction until you have checked all the components and hardware and the furniture is fully assembled.
5. Assemble all components loosely until advised to tighten. Depending on use, it may be necessary to tighten the components from time to time, so please save the tools that have been provided.
6. Please keep all small pieces out of reach of children.

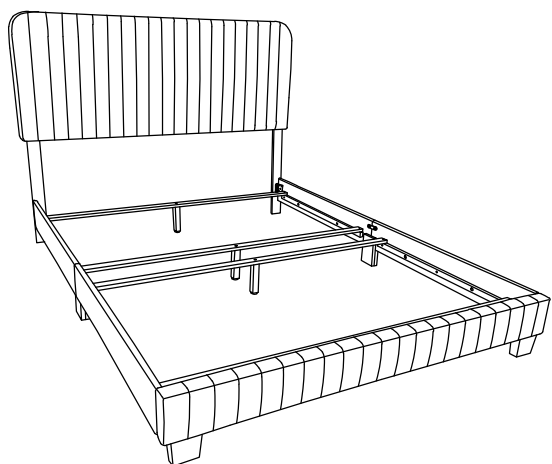

Hardware

A		Allen Key M4	x1
B		Allen Key M5	x1
C		Side Rail Connect	x2
D		JCBC Bolt M6 x 15mm	x4
E		JCBC Bolt M6 x 35mm	x8
F		JCBC Bolt M6 x 40mm	x6
G		Spring Washer	x14
H		Flat Washer	x10
I		CBS Screw M4 x 32mm	x8
J		JCCA Bolt M6 x 50mm	x4
K		JCBB M8 x 16mm	x8

COMPONENT

- 1- Headboard
- 2- Footboard
- 3- Side Rail Right
- 4- Side Rail Left
- 5- Support Leg
- 6- Footboard Leg
- 7- Side Rail Leg
- 8- Slats
- 9- Headboard Left Leg
- 10- Headboard Right Leg

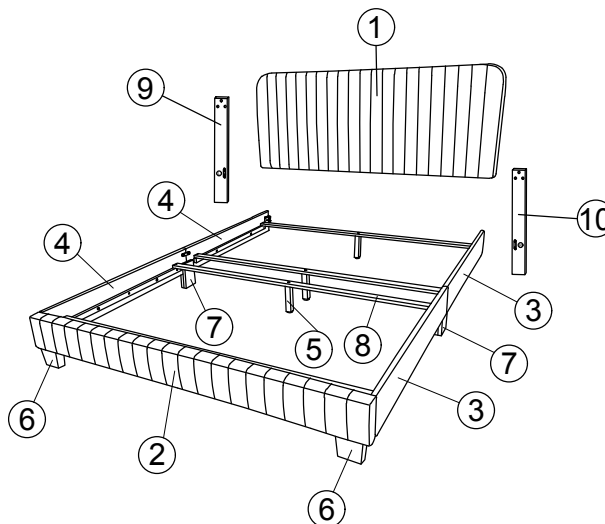

MOD-6330

STEP 1 :

1- Unzip the cover at the back-facing of the **Headboard(1)** and unpack the hardware & headboard parts as shown.

2- Secure the **Right Leg (10) & Left Leg (9)** using **JCBC Bolt 40mm (F)**, **Spring Washer (G)**, **Flat Washer (H)**, tighten with **Allen Key (A)**.

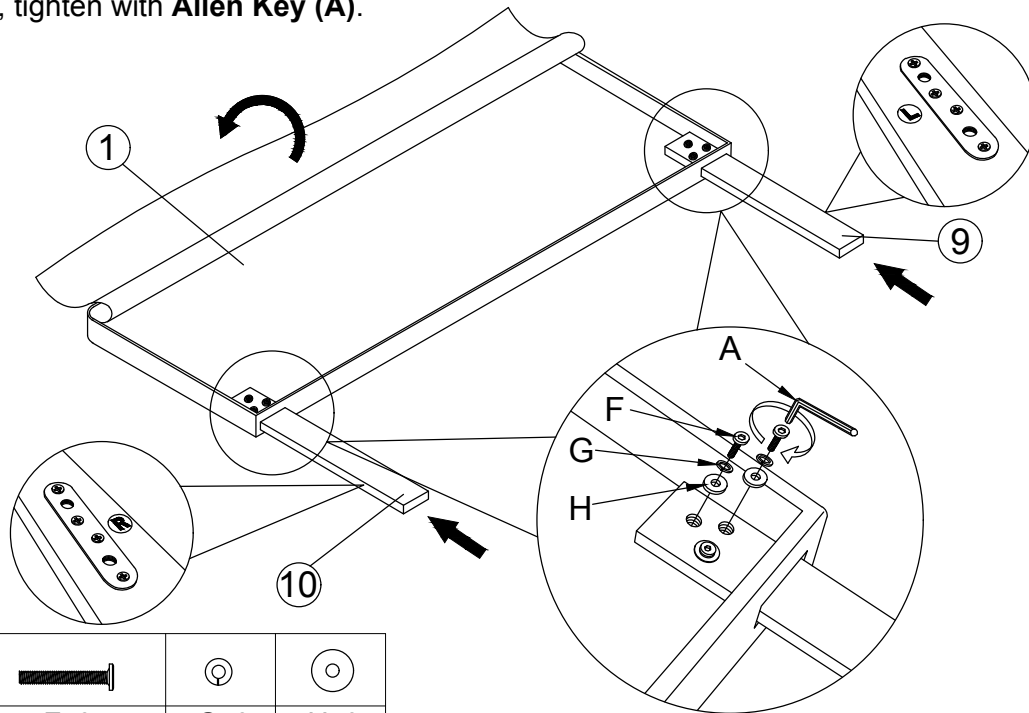

Ax1	Fx6	Gx6	Hx6

Hardware & Tool required

STEP 2 :

Attach the **Footboard Leg (6)** (2pcs) to **Footboard (2)** use **JCCA Bolt 50mm (J)** and **Allen Key (A)** to fix.

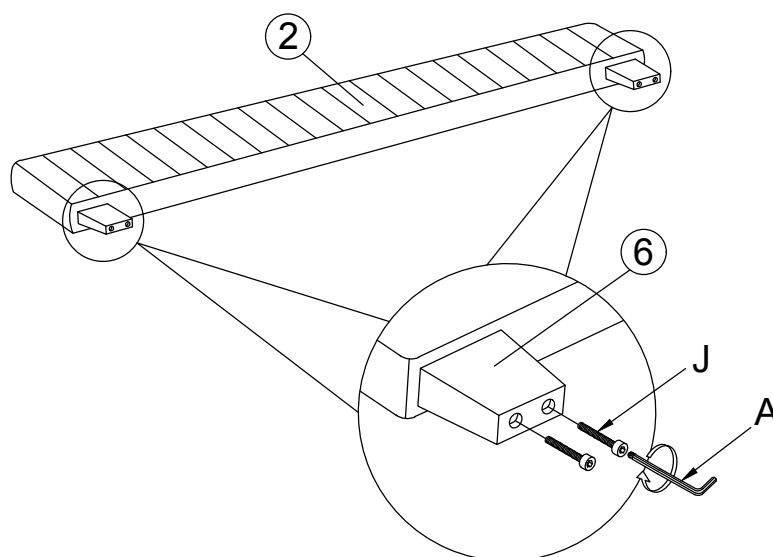

Ax1	Jx4

Hardware & Tool required

STEP 3 :

Attach the **Slat (8)** to **Support Leg (5)**. Use **JCBC Bolt 35mm (E)** and **Allen Key (A)** to fix.

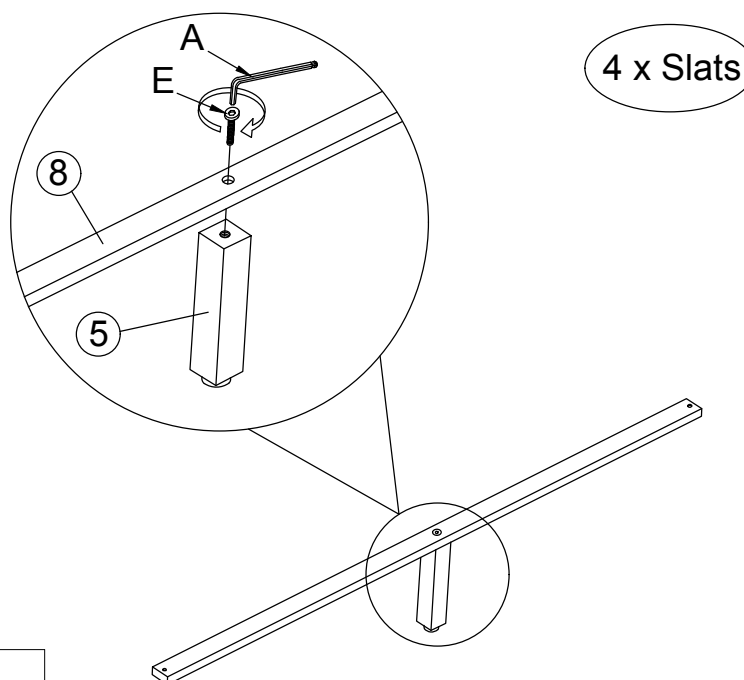

Ax1	Ex4

Hardware & Tool required

STEP 4 :

Attach and tighten the **Side Rail Right (3)** (2pcs) and **Side Rail Left (4)** (2pcs) to **Side Rail Leg (7)** (2pcs). On the Side Rail use **Side Rail Connect (C)**, **Spring Washer (G)**, **JCBC Bolt 15mm (D)** and **Allen Key (A)** to fix. On the Side Rail Leg use **JCBC Bolt 35mm (E)**, **Spring Washer (G)**, **Flat Washer (H)** and **Allen Key (A)** to fix.

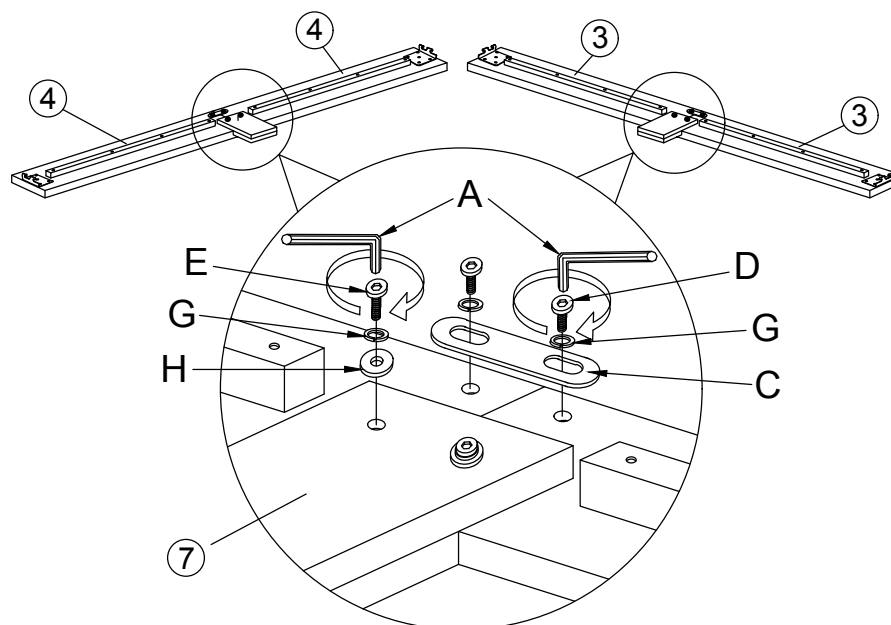

Ax1	Cx2	Dx4	Ex4	Gx8	Hx4

Hardware & Tool required

STEP 5 :

Attach both **Side Rail (3&4)** to the bracket of **Headboard (1)** and **Footboard (2)**.
Use **JCBB Bolt 16mm (K)** and **Allen Key (B)** to fix.

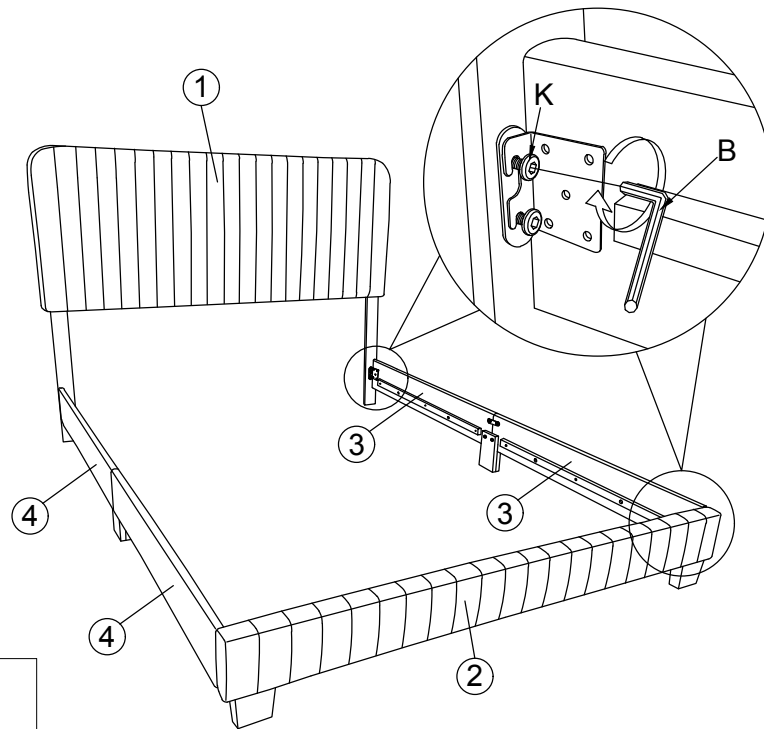

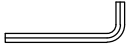
	
Bx1	Kx8

Hardware & Tool required**STEP 6 :**

Attach and tighten the **Slats (8)** to Side Rail.
Adjusting the leg adjuster to the floor.
Use **CBS Screw 32mm (I)** and screwdriver to fix.

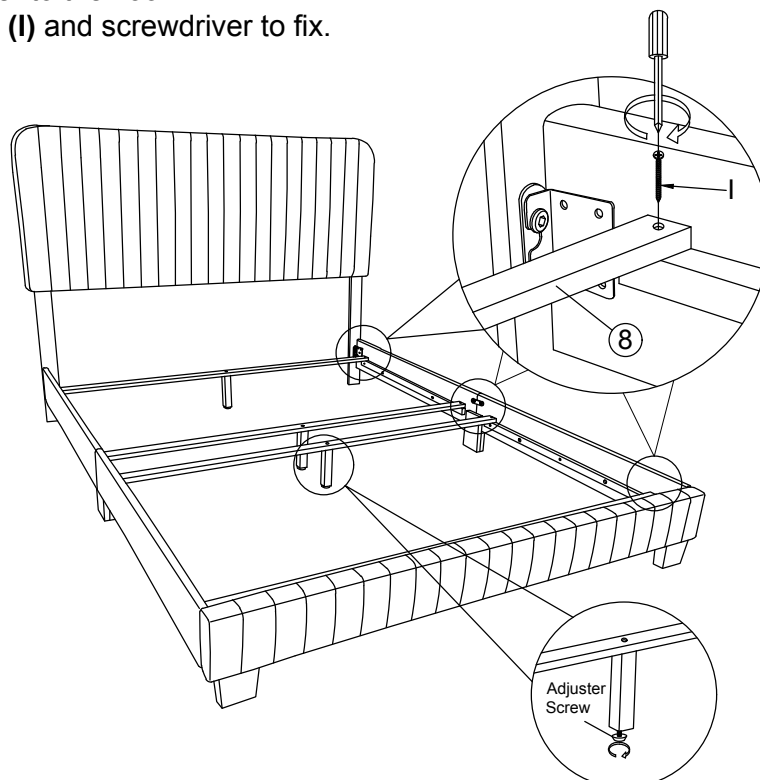

Ix8

Hardware & Tool required