



Thank you for purchasing the **MODWAY OFFICE CHAIR** !

Before you start, here is some helpful advice:

1. We suggest you spend a short time reading through this leaflet and then follow the simple step by step instructions.
2. Owing to the size and weight of the office chair, we recommend that it is assembled by two adults, on a carpeted or padded area, in the room that it is intended for. Approximate assembly time: 15 minutes.
3. Please do not use any tools other than those provided or recommended in these instructions.
4. Please do not throw away any of the packaging or instructions until you have checked all the components and hardware and the furniture is fully assembled.
5. Assemble all components loosely until advised to tighten. Depending on use, it may be necessary to tighten the components from time to time, so please save the tools that have been provided.
6. Please keep all pieces out of reach of small children.



Hardware:

1		Bolt M6x18mm	x8
2		Allen Wrench	x1
3		Plastic Cover	x6

Component:

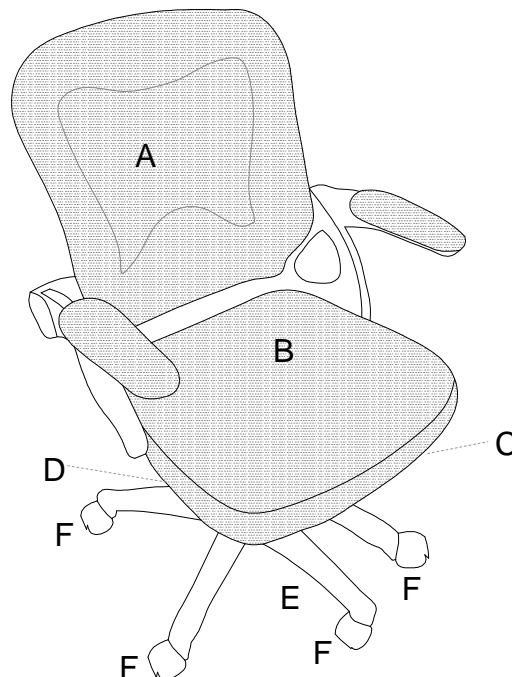

A	Chair Back with Arm	x1	B	Chair Seat	x1	C	Control Mechanism	x1
D	Cylinder Column	x1	E	Chair Base	x1	F	Castor	x5

STEP 1:

Please put the **Chair Base (E)** upside down on a carpeted or padded surface.

Insert 1pc of **Castor (F)** into the **Chair Base (E)** as shown by hand.

Repeat the same steps for the other 4pcs of **Castor (F)**.

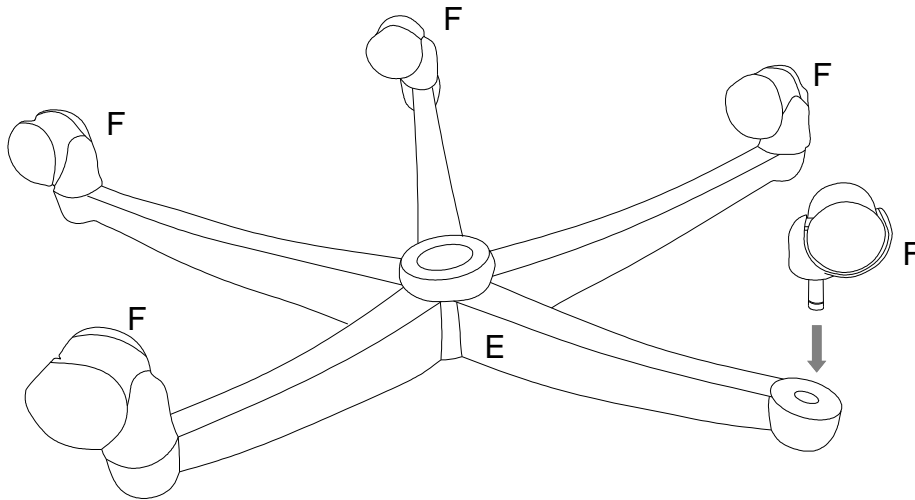

STEP 2:

Place a sealed carton on the floor with a carpeted or padded surface on the top side of carton.

Please put a heavy object into the carton for balance prior to assembling the office chair.

Place the **Chair Seat (B)** upside down on the carton.

Attach the **Chair Back with Arm (A)** into the bottom of **Chair Seat (B)** by using 6 piece of **Bolts (1)** as shown.

Use **Allen Wrench (2)** to tighten the **Bolts (1)** clockwise until secure.

Insert the 6 pieces of **Plastic Covers (3)** into the corresponding holes on the side of **Chair Back with Arm (A)** as shown.

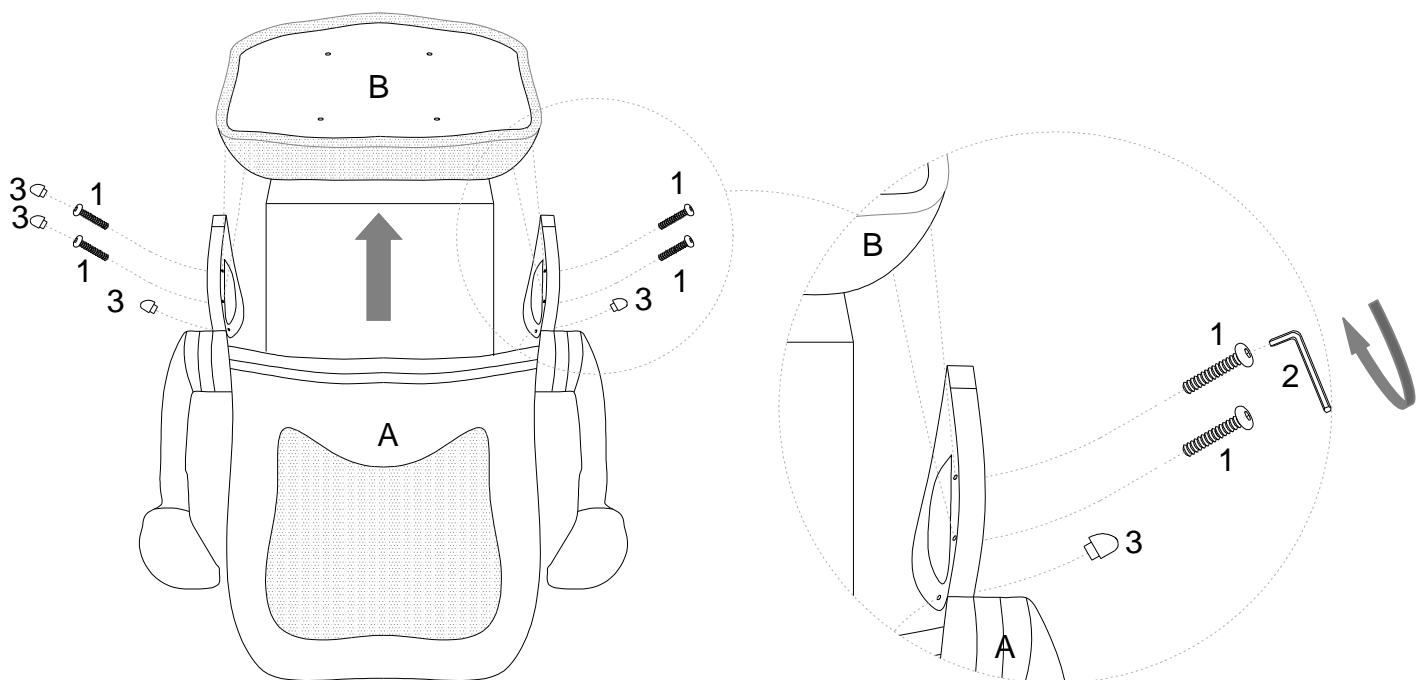

1x4pcs	2x1pc	3x6pc

Hardware & Tool required

STEP 3:

Attach the **Control Mechanism (C)** into the bottom of **Chair Seat (B)** by using 4 piece of **Bolts (1)** as shown.

Use **Allen Wrench (2)** to tighten the **Bolts (1)** clockwise until secure.

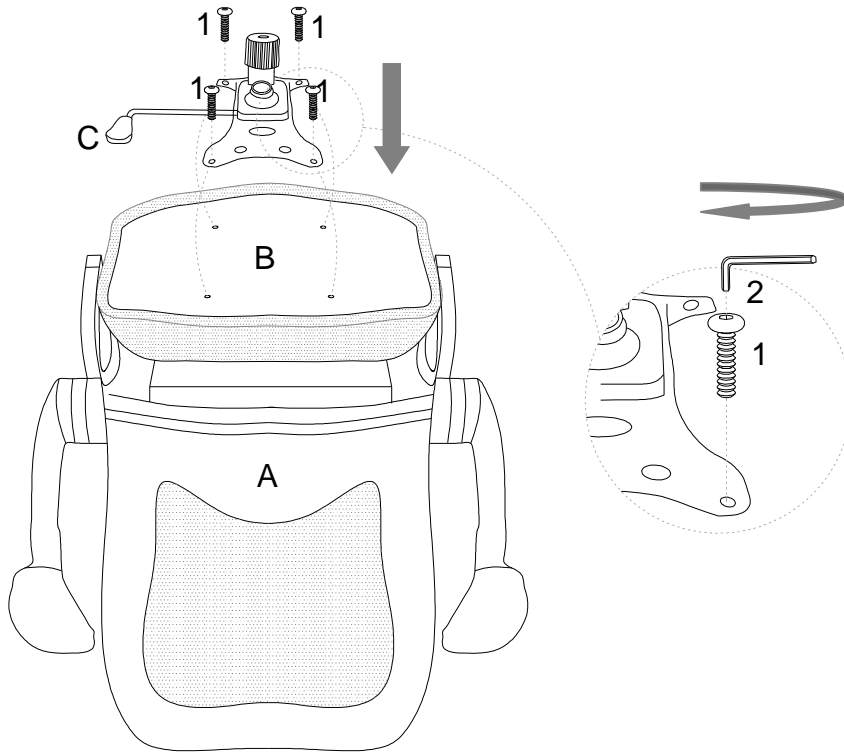

	
1x4pcs	2x1pc

Hardware & Tool required

STEP 4:

Insert the **Cylinder Column (D)** into the Bottom of **Control Mechanism (C)** as shown.

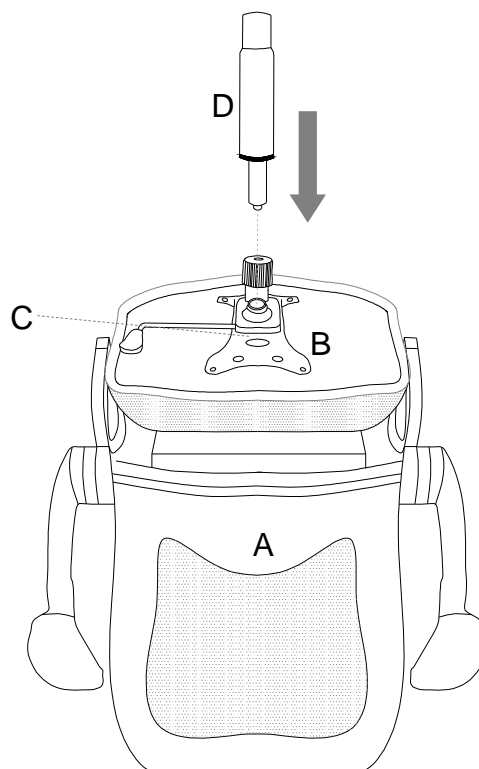

STEP 5:

Insert the assembled **Chair Base (E)** into the **Cylinder Column (D)** as shown.

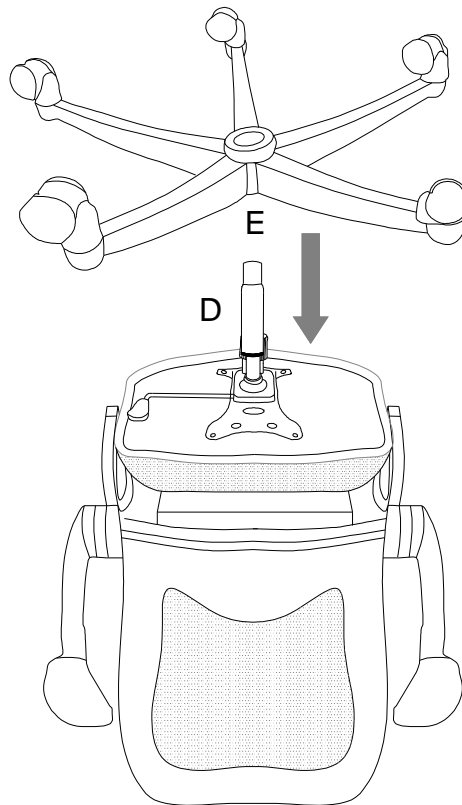

STEP 6:

Carefully turn over the office chair.

Place the armrests to the correct position for using.

