

Thank you for purchasing the **MODWAY TV Stand** !

Before you start, here are some helpful advice:

1. We suggest you spend a short time reading through this leaflet and then follow the simple step-by-step instructions.
2. Owing to the size and weight of the Tv Stand, we recommend that it is assembled by two adults, on a carpeted or padded area, in the room that it is intended for. Approximate assembly time: 60 minutes.
3. Please do not use any tools other than those provided or recommended in these instructions.
4. Please do not throw away any of the packaging or instructions until you have checked all the components and hardware and the furniture is fully assembled.
5. Assemble all components loosely until advised to tighten. Depending on use, it may be necessary to tighten the components from time to time, so please save the tools that have been provided.
6. Please keep all pieces out of reach of children.

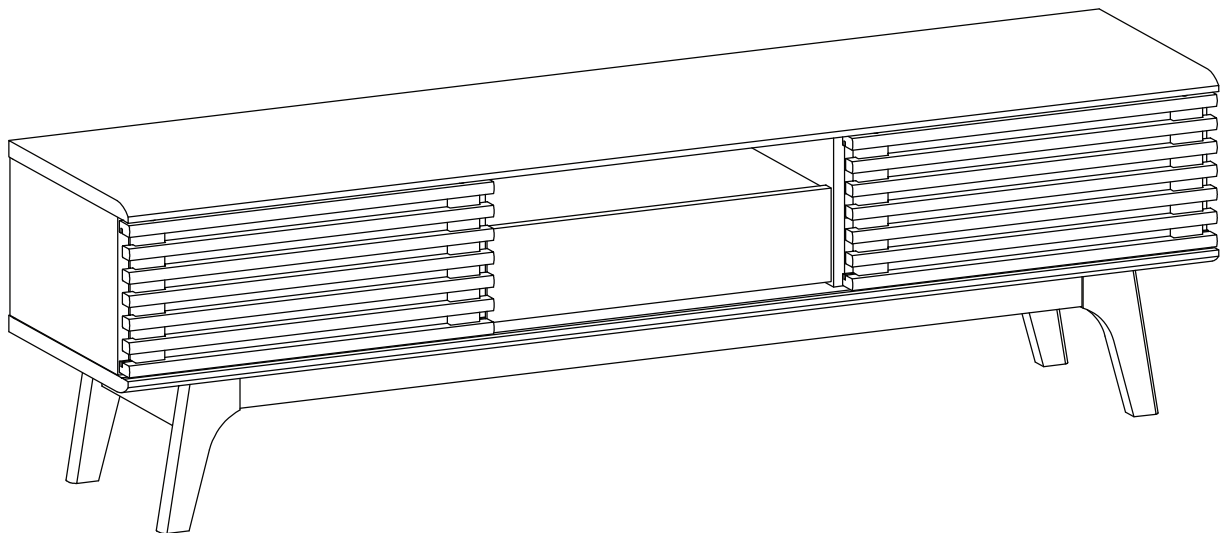

## Hardware :

|  |  |   |  |   |
|--|--|---|--|---|
| <b>A)</b> Cambolt/Metal<br><br>$\varnothing$ 6 x 35 mm x12 | <b>B)</b> CamLock Big/Metal<br><br>$\varnothing$ 15 mm x10           | <b>C)</b> CamLock Small/Metal<br><br>$\varnothing$ 12 mm x 2            | <b>D)</b> Dowel Big/Wood<br><br>$\varnothing$ 8 x 30 mm x 52 | <b>E)</b> Dowel Small/Wood<br><br>$\varnothing$ 6 x 30 mm x 2 |
| <b>F)</b> Reil/Metal<br><br>250 mm x 1                     | <b>G)</b> Screw/Metal<br><br>M 6.5 x 10.5 mm x 4                     | <b>H)</b> Screw/Metal<br><br>M 3.5 x 13 mm x 4                          | <b>I)</b> Screw/Metal<br><br>M 8 x 39 mm x 4                 | <b>J)</b> Screw/Metal<br><br>M 7 x 50 mm x 6                  |
| <b>K)</b> Key/Metal<br><br>L 4 x 1                         | <b>L)</b> Screw/Metal<br><br>M 12 x 35 mm x 8                        | <b>M)</b> Shelf Pin/Metal<br><br>$\varnothing$ 5 x 15 mm x 8            | <b>N)</b> Wedge/Plastic<br><br>9 x 14 x 10 mm x 12           | <b>O)</b> Screw/Metal<br><br>M 3.5 x 15.5 mm x 12             |
| <b>P)</b> Stoper/Plastic<br><br>42 x 14 x 8 mm x 2         | <b>Q)</b> Pin Sliding Top/Plastic<br><br>$\varnothing$ 8 x 19 mm x 4 | <b>R)</b> Pin Sliding Bottom/Plastic<br><br>$\varnothing$ 8 x 16 mm x 4 | <b>S)</b> Buffer/Rubber<br><br>$\varnothing$ 8 mm x 2        | <b>T)</b> Screw Cup/Plastic<br><br>$\varnothing$ 15 mm x 6    |
| <b>U)</b> Foam Pad/Spon<br><br>25 x 25 x 2 mm x 4          | <b>V)</b> Screwdriver (Not Include)<br><br>x 1                       |   |  |   |

Components:

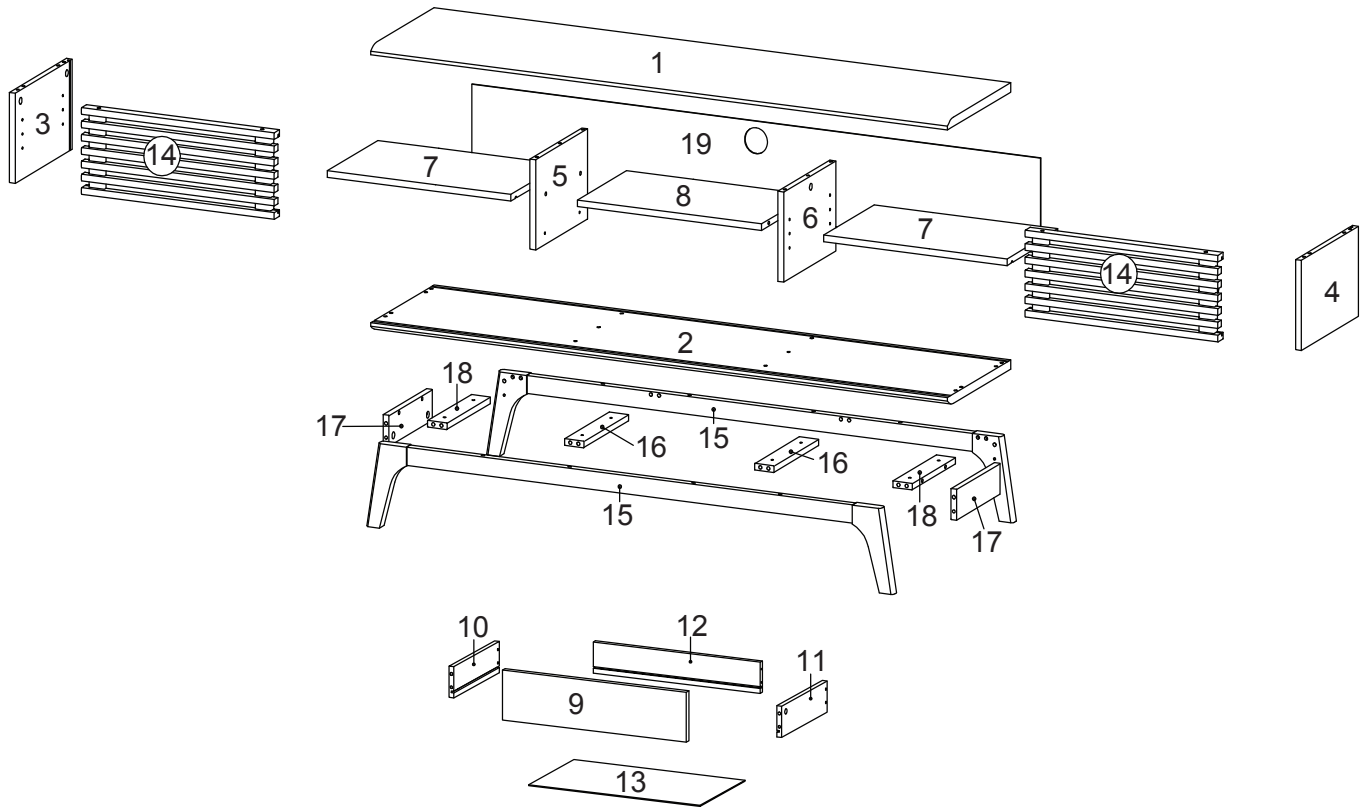

|    |                   |    |    |                    |    |    |                   |    |    |                  |    |
|----|-------------------|----|----|--------------------|----|----|-------------------|----|----|------------------|----|
| 1  | Top Board         | x1 | 2  | Bottom Board       | x1 | 3  | Side Board Left   | x1 | 4  | Side Board Right | x1 |
| 5  | Centre Board Left | x1 | 6  | Centre Board Right | x1 | 7  | Adjustable Shelf  | x2 | 8  | Fixed Shelf      | x1 |
| 9  | Front Drawer      | x1 | 10 | Side Drawer Left   | x1 | 11 | Side Drawer Right | x1 | 12 | Back Drawer      | x1 |
| 13 | Bottom Drawer     | x1 | 14 | Sliding Door       | x2 | 15 | Leg               | x2 | 16 | Support Board 1  | x2 |
| 17 | Support Board 2   | x2 | 18 | Support Board 3    | x2 | 19 | Back Board        | x1 |    |                  |    |

STEP 1:

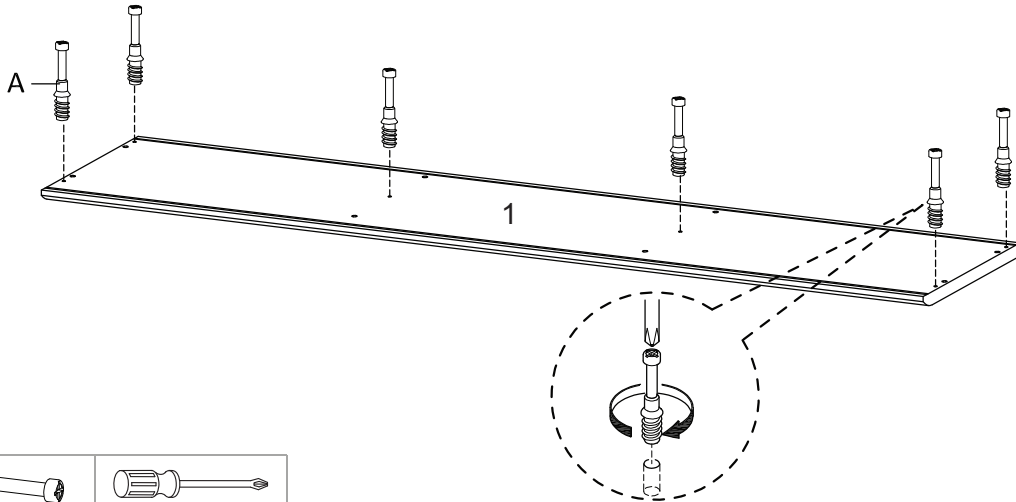

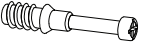
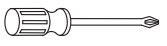

|   |   |
|---|---|
|  |  |
| Ax6   | Vx1   |

Hardware required. Screwdriver not included

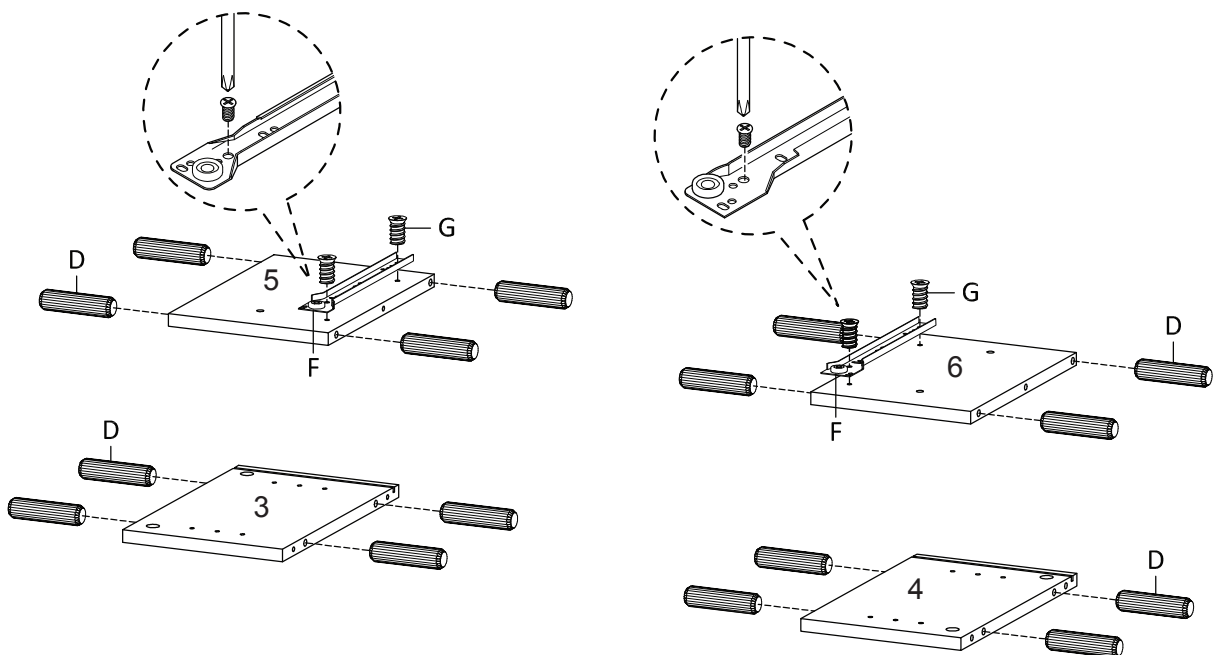
STEP 2:

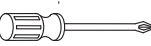

|   |   |   |   |
|---|---|---|---|
|  |  |  |  |
| Dx16  | Fx1   | Gx4   | Vx1   |

Hardware required. Screwdriver not included

STEP 3:

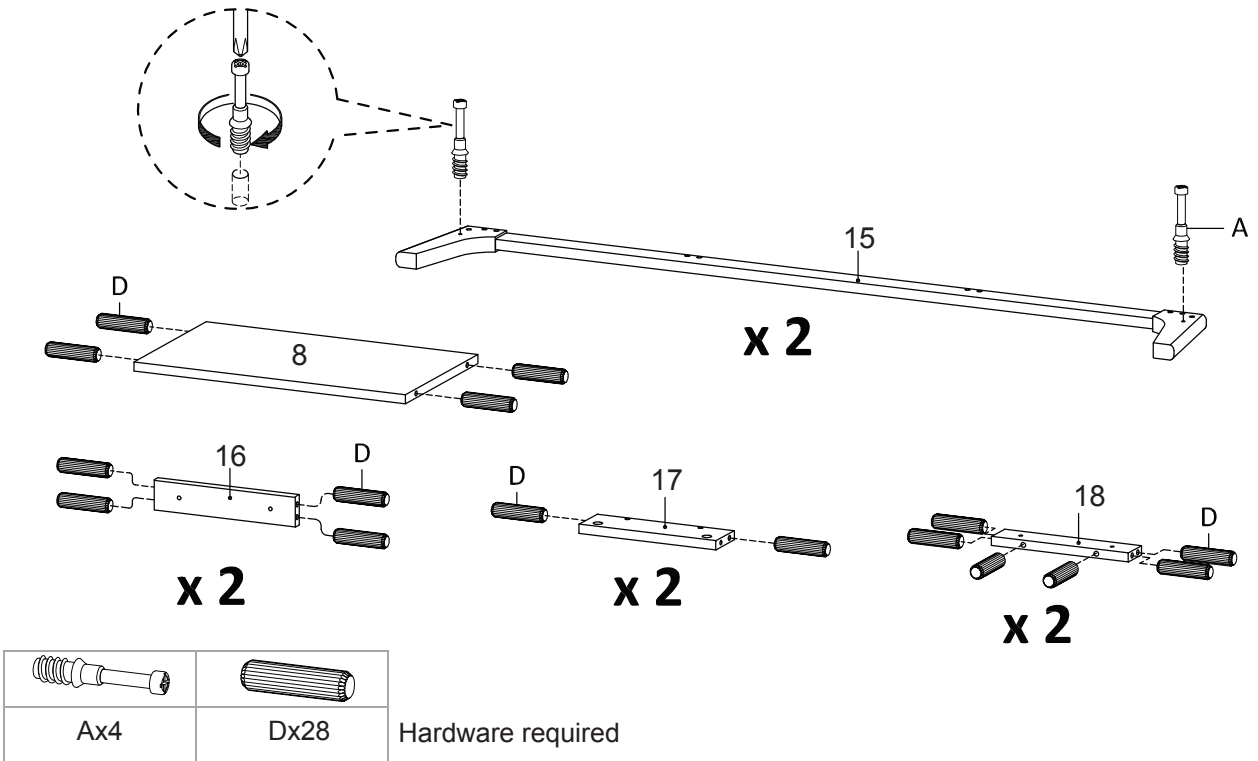

STEP 4:

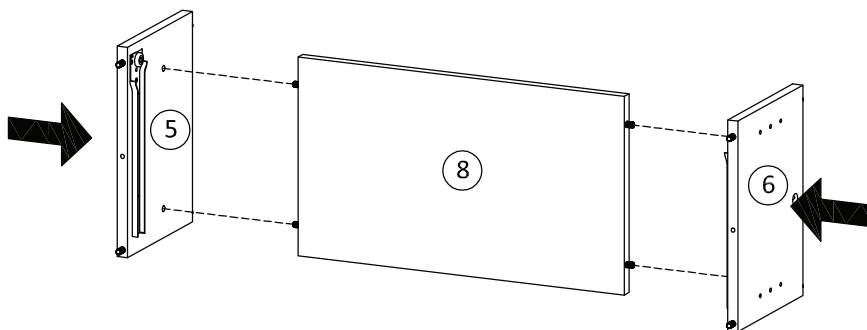

STEP 5:

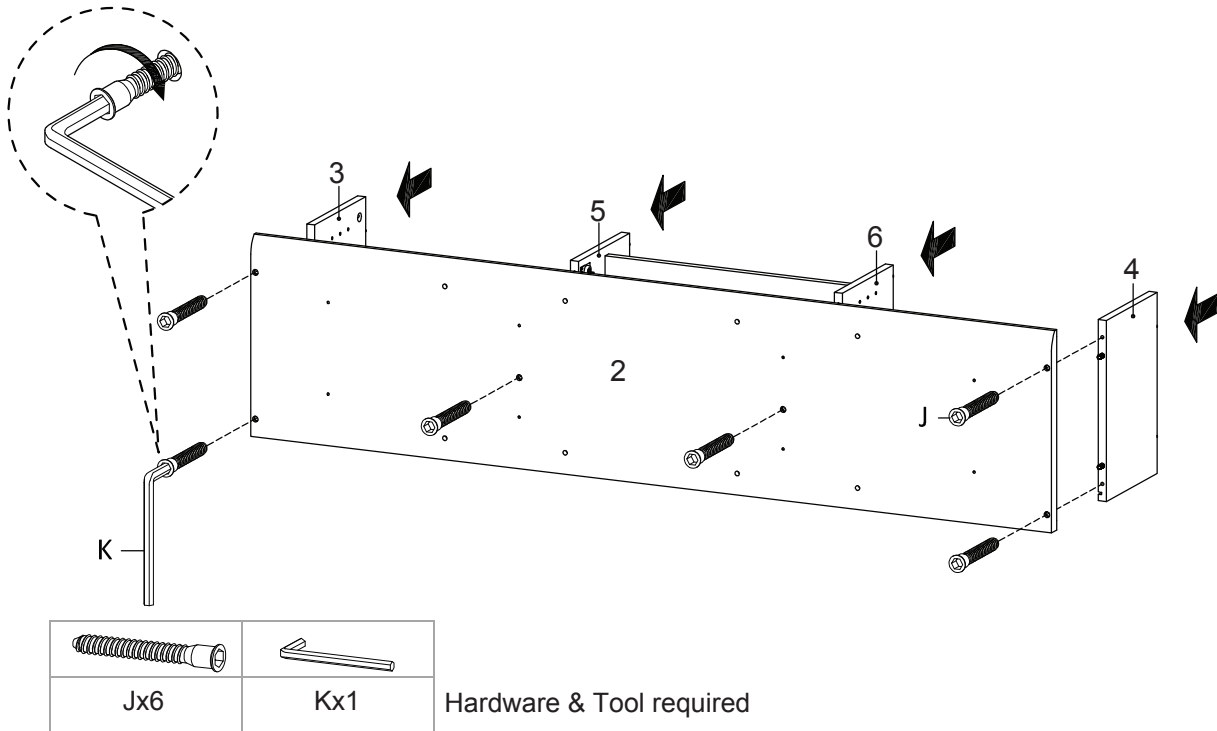

STEP 6:

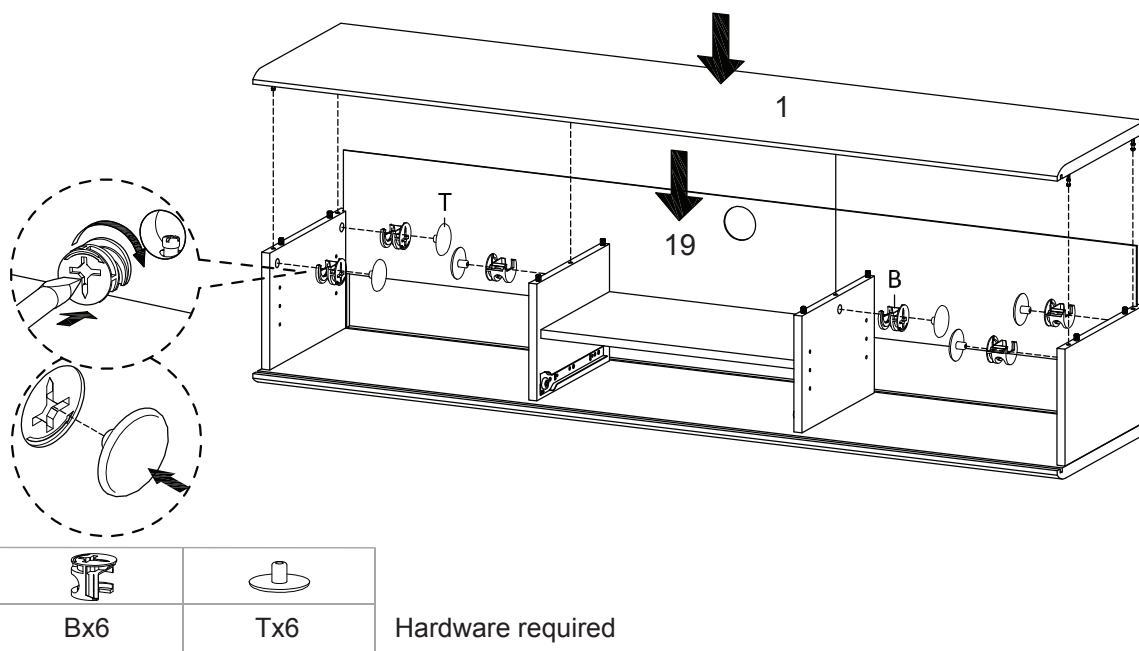

**STEP 7:**

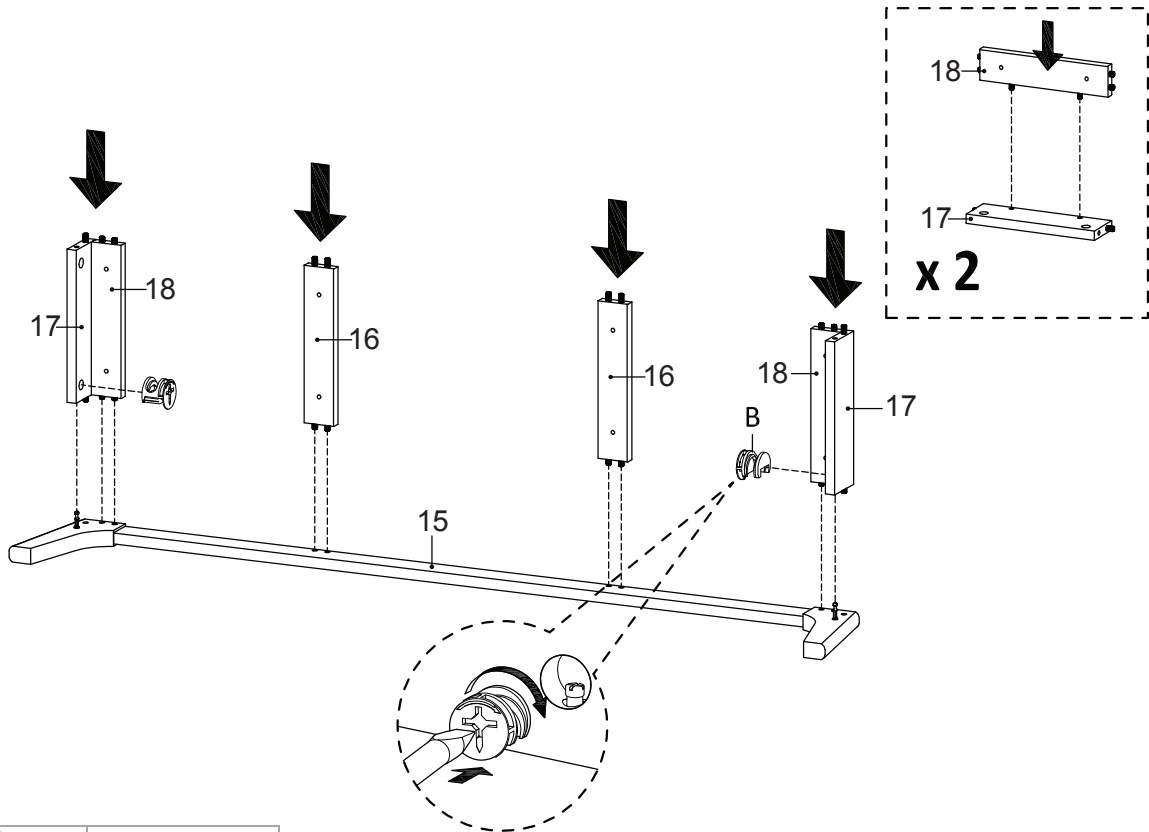

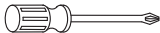

|   |   |
|---|---|
|  |  |
| Bx2   | Vx1   |

Hardware required. Screwdriver not included

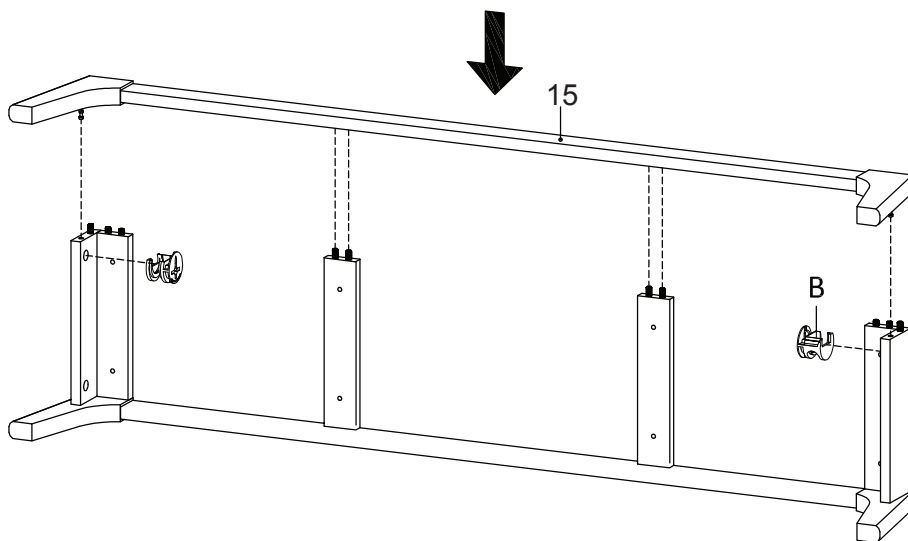
**STEP 8:**



|   |   |
|---|---|
|  |  |
| Bx2   | Vx1   |

Hardware required. Screwdriver not included

STEP 9:

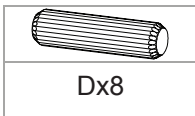
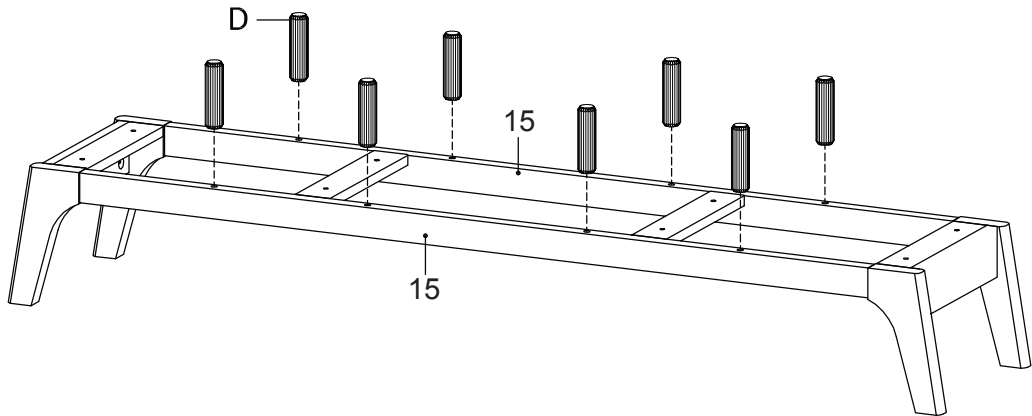

Dx8

Hardware required

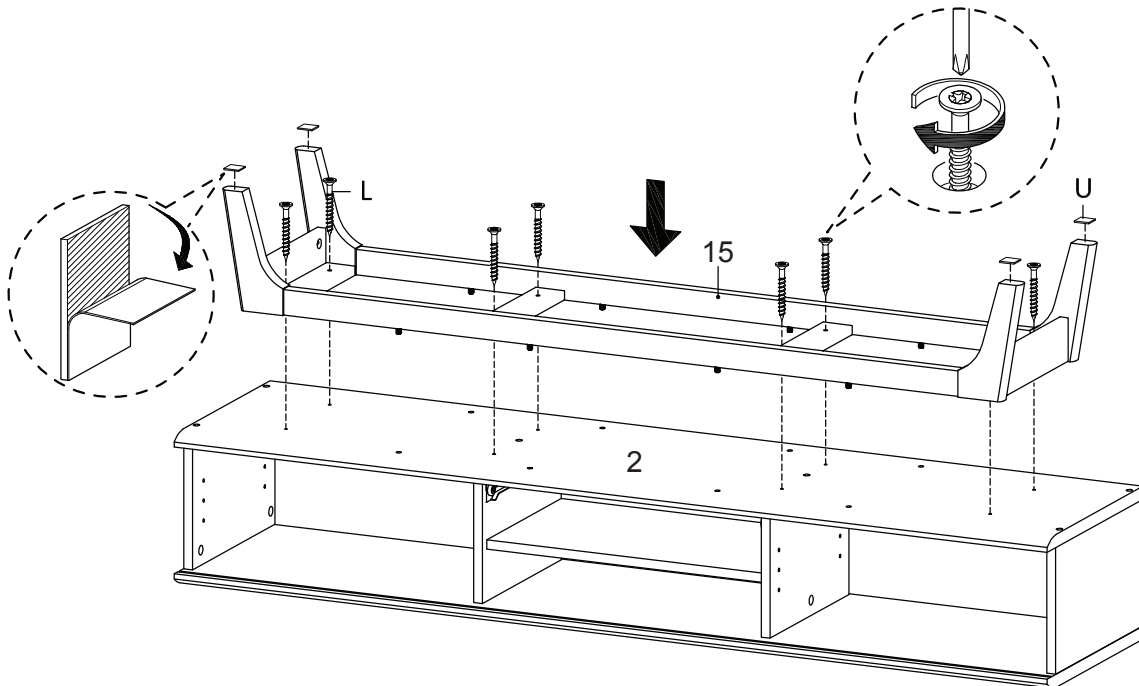

STEP 10:

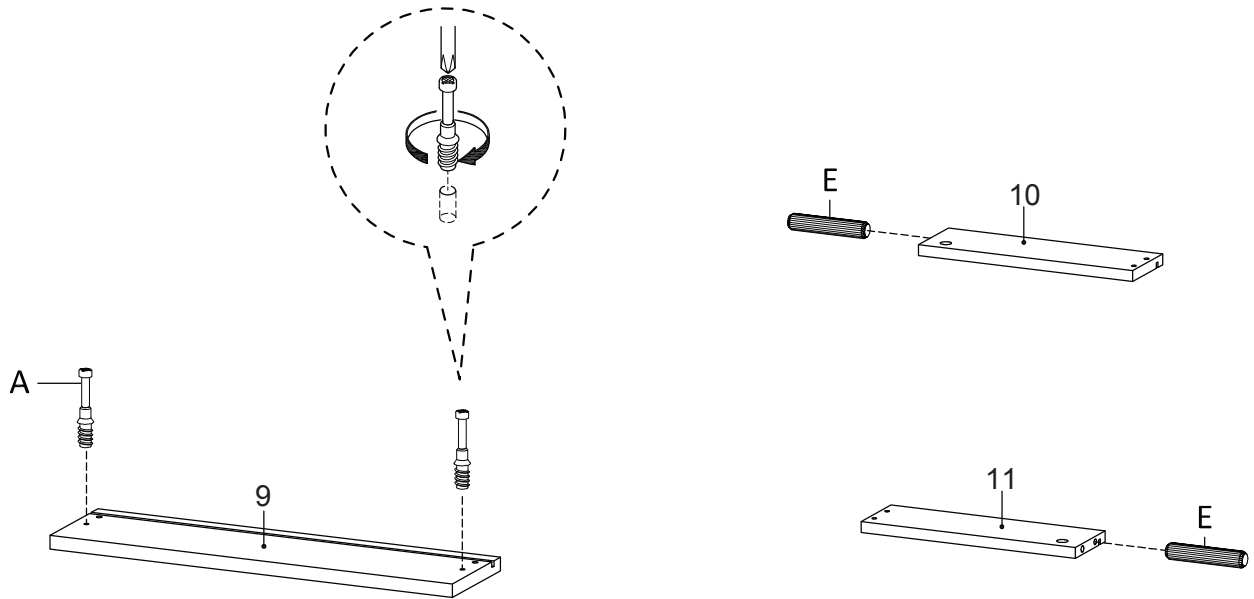

Hardware required. Screwdriver not included

**STEP 11:**

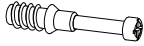



|   |   |   |
|---|---|---|
|  |  |  |
| Ax2   | Ex2   | Vx1   |

Hardware required. Screwdriver not included

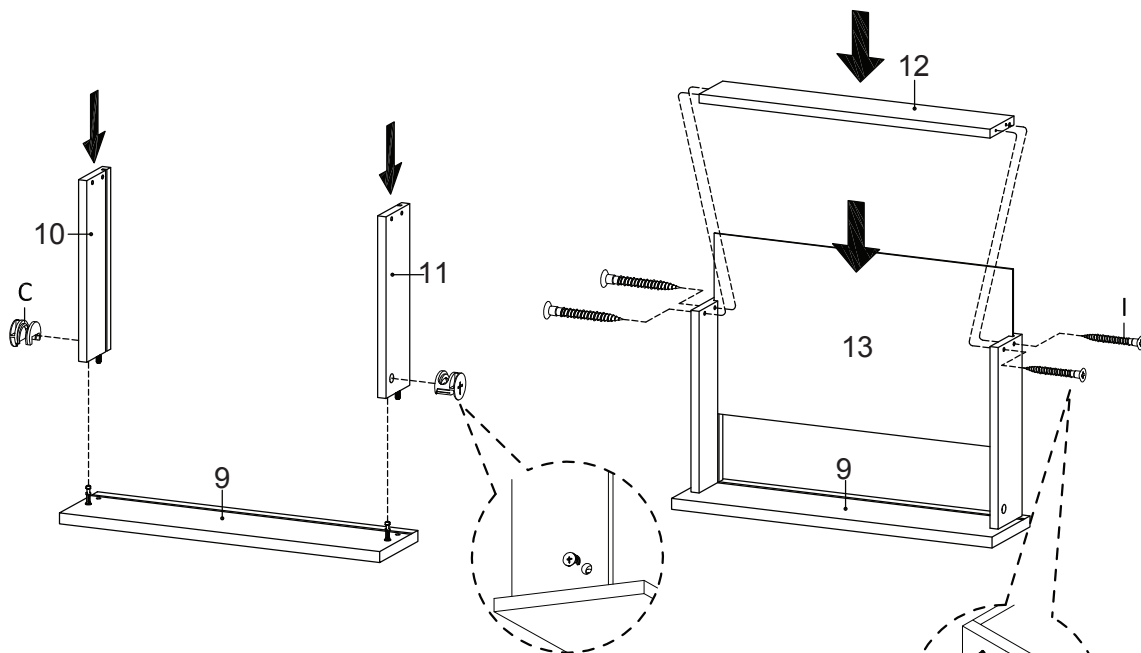
**STEP 12:**





|   |   |   |
|---|---|---|
|  |  |  |
| Cx2   | Ix4   | Vx1   |

Hardware required.  
Screwdriver not included

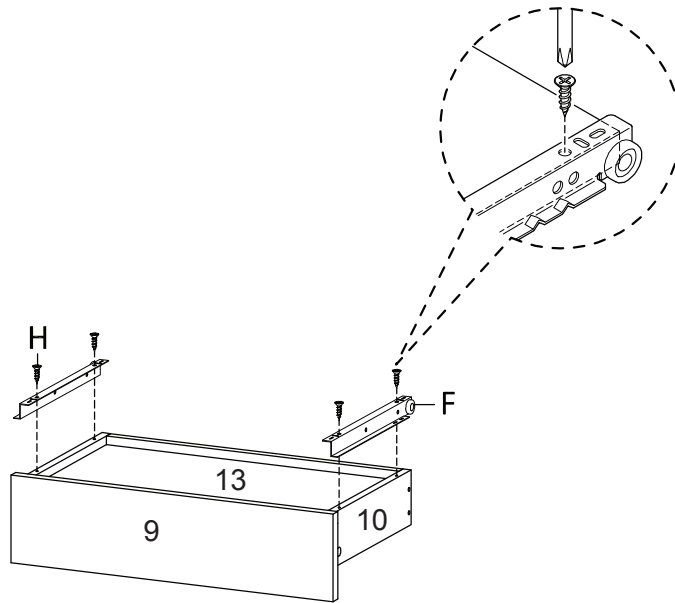

STEP 13:

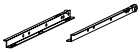

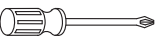
|   |   |   |
|---|---|---|
|  |  |  |
| Fx1   | Hx4   | Vx1   |

Hardware required. Screwdriver not included

STEP 14:

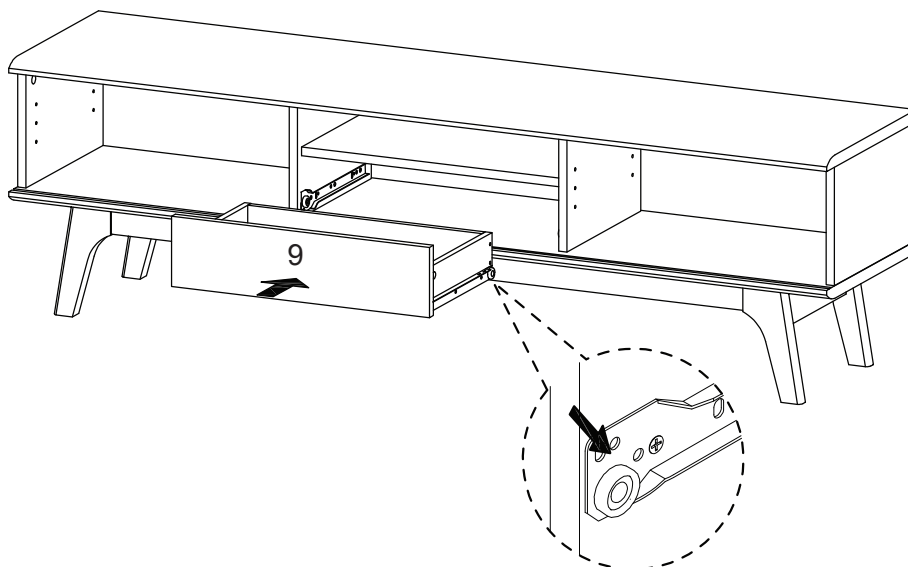

STEP 15:

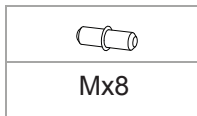
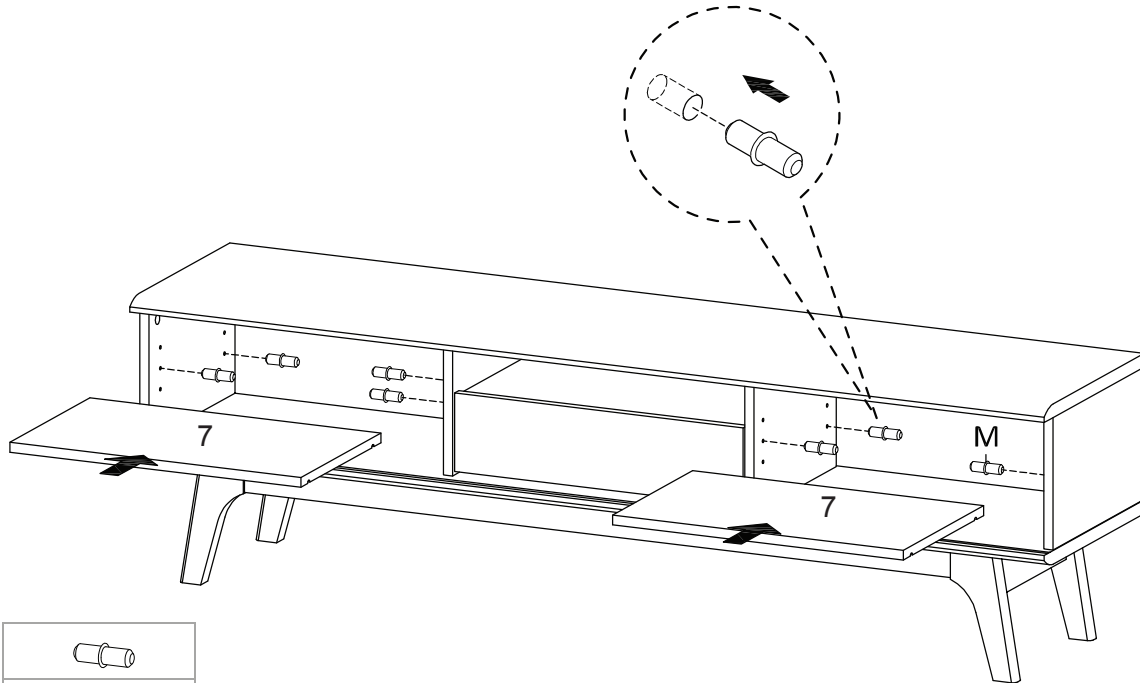

Mx8

Hardware required

STEP 16:

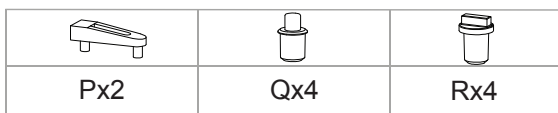
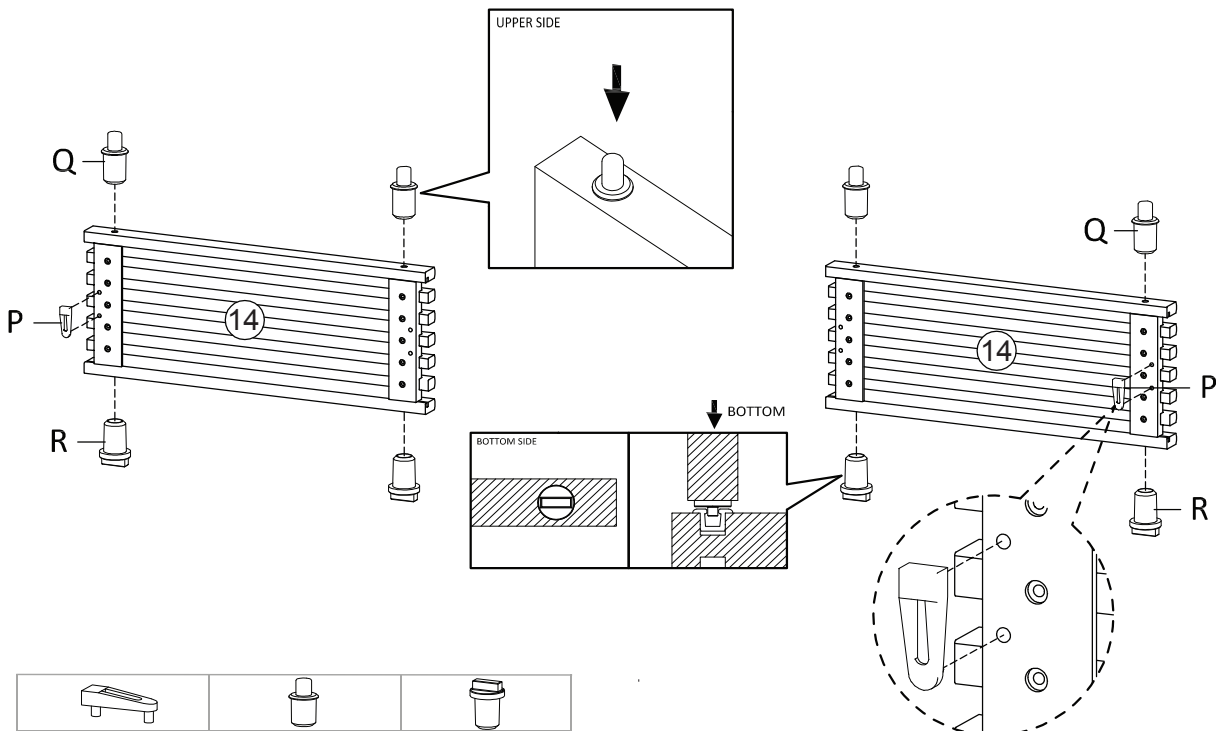

Hardware required

STEP 17:

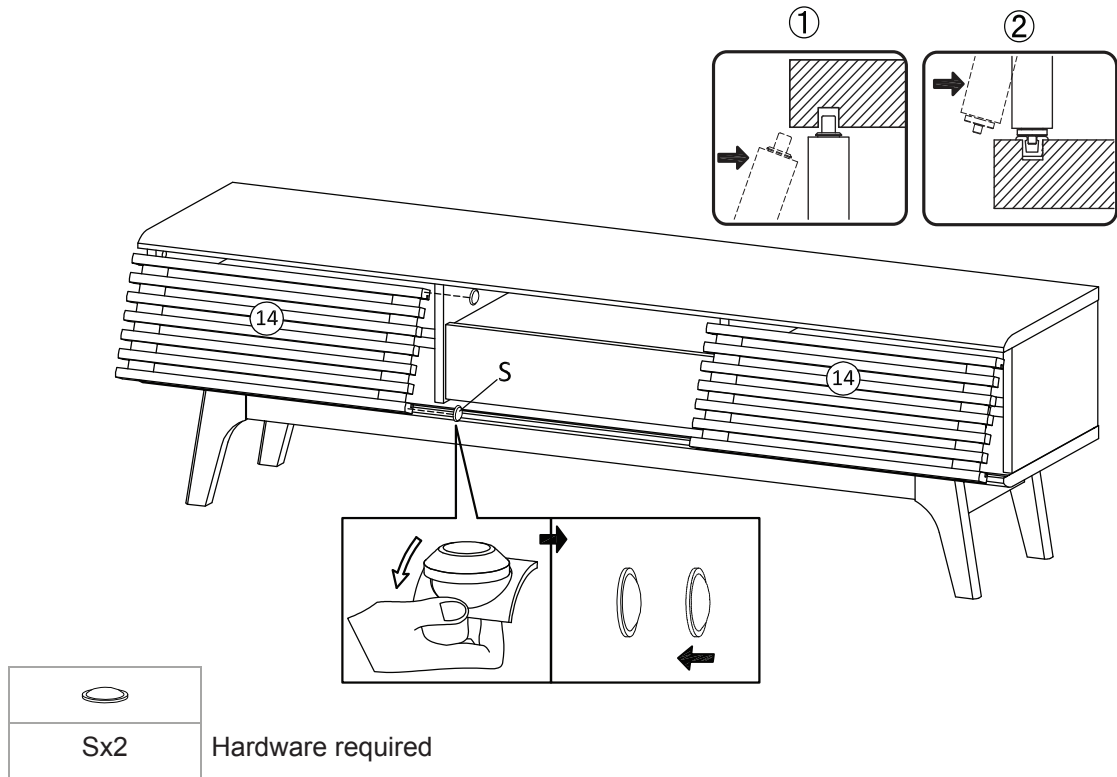

STEP 18:

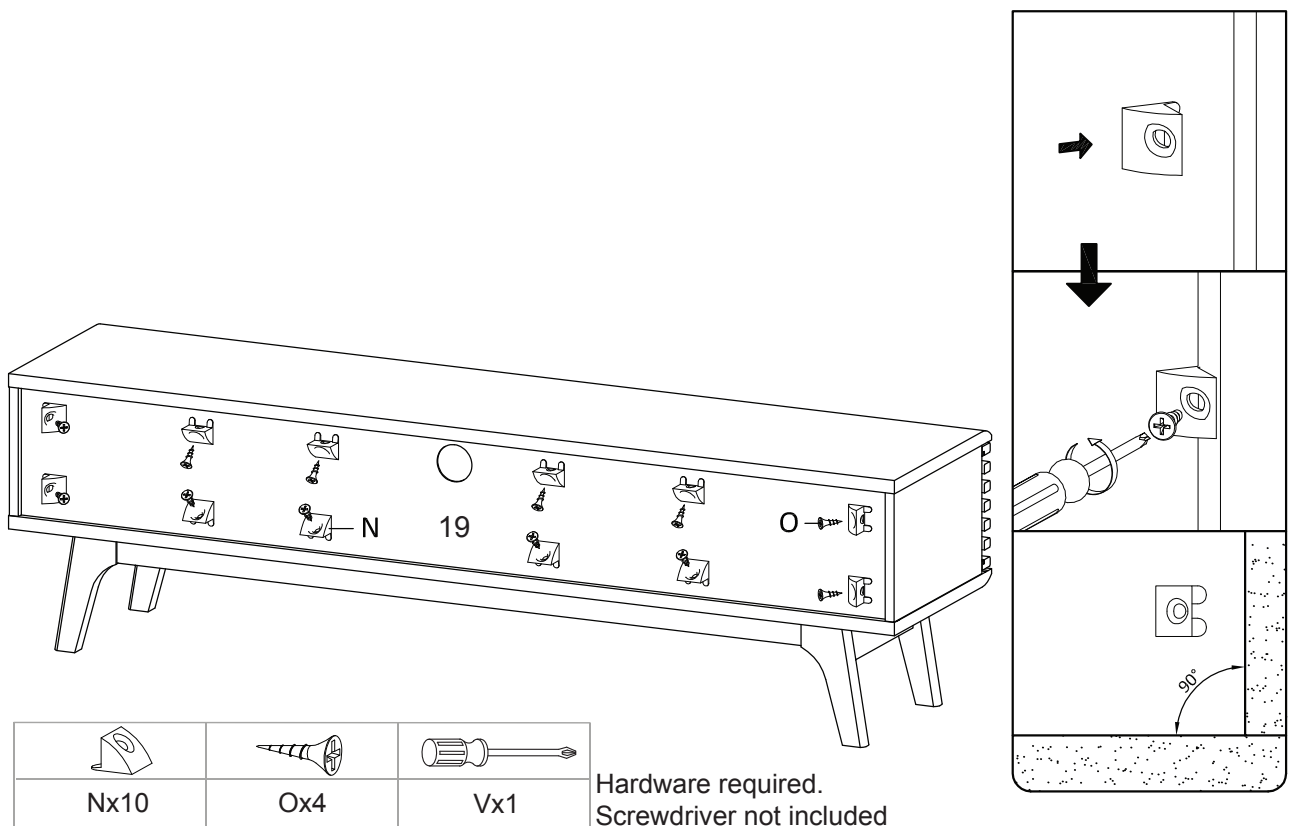

**STEP 19:**

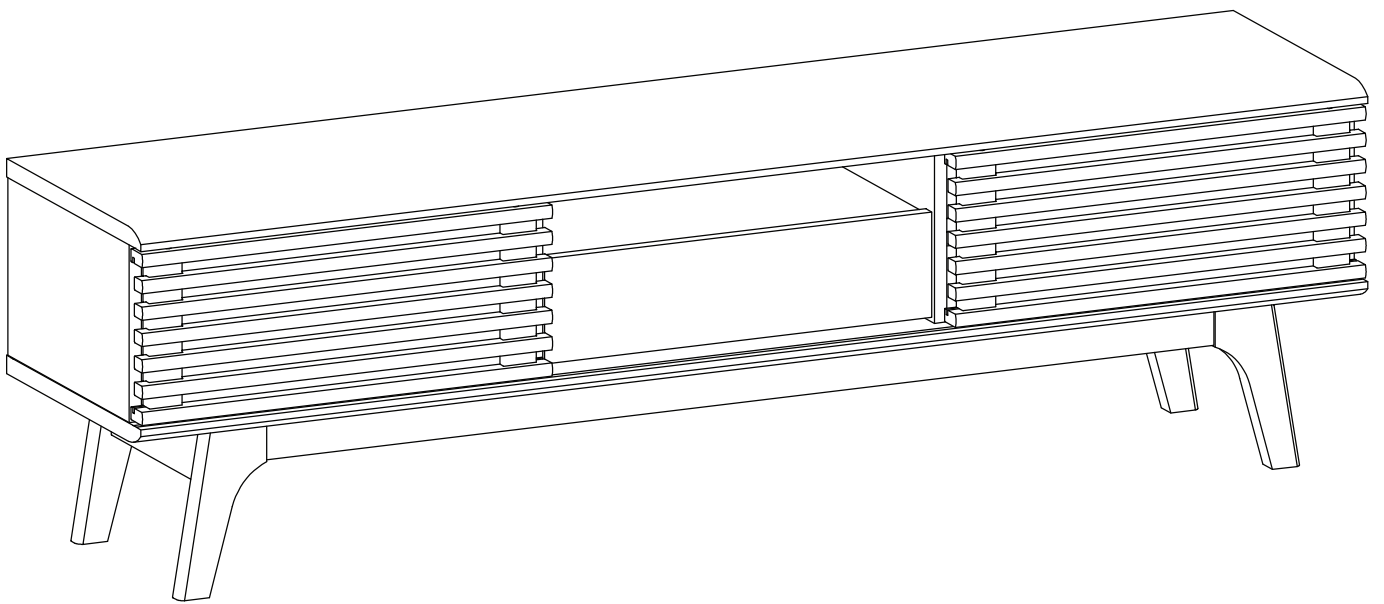

**Assembly is complete. The TV Stand is ready to enjoy now !**