





Thank you for purchasing the **MODWAY TABLE!**

Before you start, here is some helpful advice:

1. We suggest you spend a short time reading through this leaflet and then follow the simple step-by-step instructions.
2. Owing to the size and weight of the table, we recommend that it is assembled by two adults, on a carpeted or padded area, in the room that it is intended for. Approximate assembly time: 30 minutes.
3. Please do not use any tools other than those provided or recommended in these instructions.
4. Please do not throw away any of the packaging or the instruction until you have checked all the components and hardware and the furniture is fully assembled. Please ensure that the packaging is disposed of in a safe and environmentally friendly way.
5. Assemble all components loosely until advised to tighten. Depending on use, it may be necessary to tighten the components from time to time, so please save the tools that have been provided.
6. Please keep all fitting out of reach of children.



Hardware:

A		Bolt M6x16mm	x16
B		Spring Washer M6	x16
C		Flat Washer M6	x16
D		Allen Wrench M4	x1

Component:

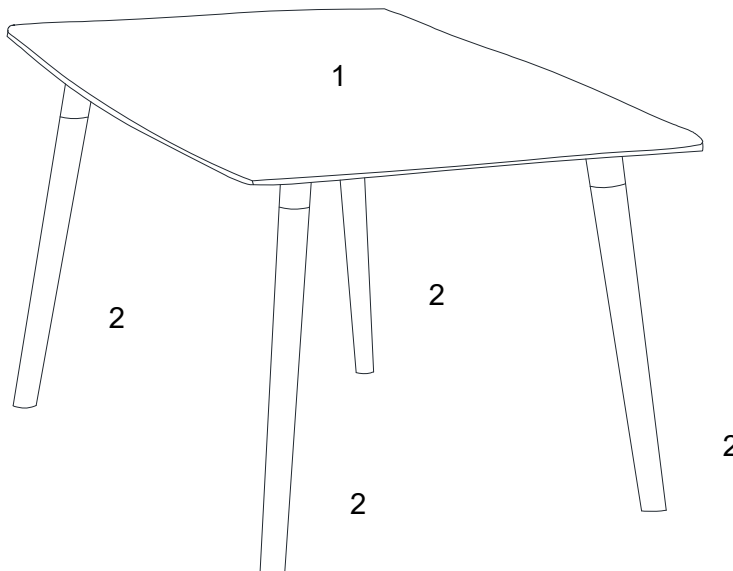

1 Table Top x1

2 Table Leg x4

STEP 1:

Please put the **Table Top (1)** upside down on a carpeted or padded area.





Position 1 piece of **Table Leg (2)** to the bottom of **Table Top (1)** as shown.

Insert 4 pieces of **Bolt (A)** with 4 pieces of **Spring Washer (B)** and 4 pieces of **Flat Washer (C)** into the hole on bottom of **Table Top (1)** through the hole on **Table Leg (2)**.

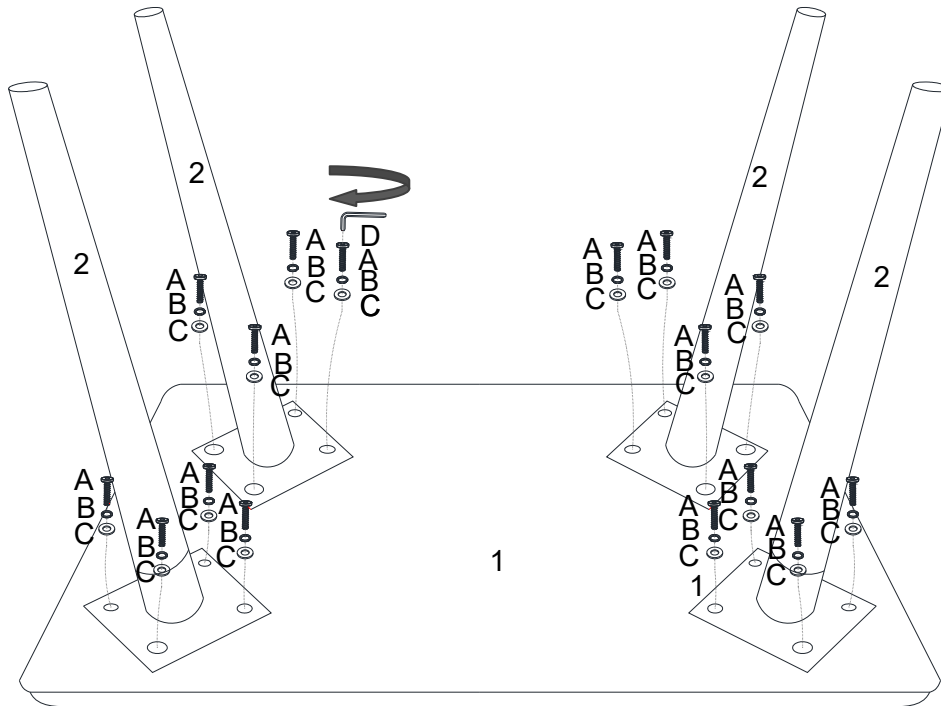
Repeat the same steps for the remaining **Table Legs (2)**.

Use **Allen Wrench (D)** to tighten **Bolt (A)** clockwise until secure.



			
Ax16	Bx16	Cx16	Dx1

Hardware & Tool required

STEP 2:

Carefully turn over the assembled table.



Assembly is complete. Your table is ready to be used now!