

EEI - 3373 SOFA

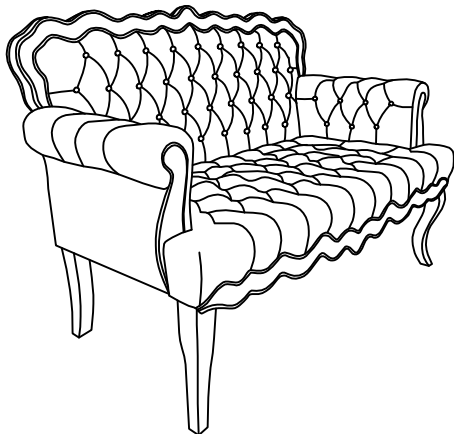









Thank you for purchasing the **MODWAY SOFA!**

Before you start, here are some helpful advice:

1. We suggest you spend a short time reading through this leaflet and then follow the simple step instructions.
2. Owing to the size and weight of the Sofa, we recommend that it is assembled by two adults, on a carpeted or padded area, in the room that it is intended for. Approximate assembly time: 25 minutes.
3. Please do not use any tools other than those provided or recommended in these instructions.
4. Please do not throw away any of the packaging or the instruction until you have checked all the components and hardware and the furniture is fully assembled. Please ensure that the packaging is disposed of in a safe environmentally friendly way.
5. Assemble all components loosely until advised to tighten. Depending on use, it may be necessary to tighten the components from time to time, so please save tools that have been provided.
6. Please keep all fitting out of reach of children.



Hardware:

1		JCBC BOLT M6 x 70	2 PCS
2		JCBB BOLT M8 x 30	12PCS
3		JCBB BOLT M8 x 45	7 PCS
4		FLAT WASHER M6	2 PCS
5		SPRING WASHER M6	2 PCS
6		FLAT WASHER M8	19PCS
7		SPRING WASHER M8	19 PCS
8		WOOD DOWEL M10 X 30mm	6 PCS
9		ALLEN KEY (BALL SHAPE) M4	1 PC
10		ALLEN KEY (BALL SHAPE) M5	1 PC
11		WOOD SCREW M4 x 32mm	4 PCS

Component:

A.	BACK	x 1
B.	SEAT	x 1
C.	ARM	x 2
D.	FRONT LEG	x 2
E.	BACK LEG	x 2

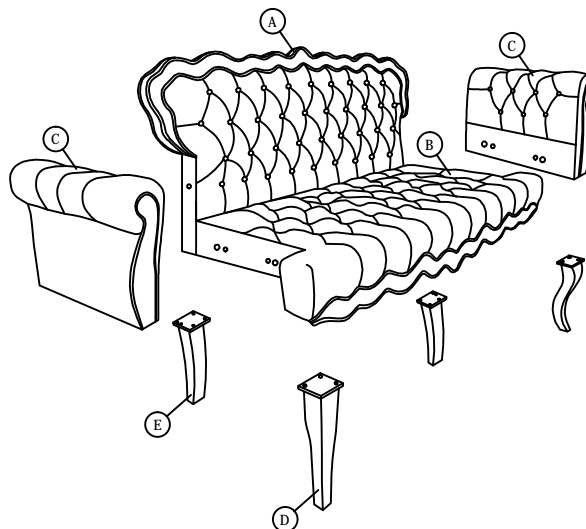

EEI - 3373 SOFA

STEP 1

- 1.1 Fit the **Wood Dowel (8)** into the pre-drilled hole of the **Back (A)**.
- 1.2 Insert and secure the **Back (A)** to the **Arm (C)** using 1 piece of **JCBC Bolt (1)**, 1 piece of **Flat Washer (4)**, and 1 piece of **Spring Washer (5)**. Use **Allen Key (9)** to tighten. (Note: Do not fully tighten until all bolts are secure). Repeat steps for the other side of the Arm.

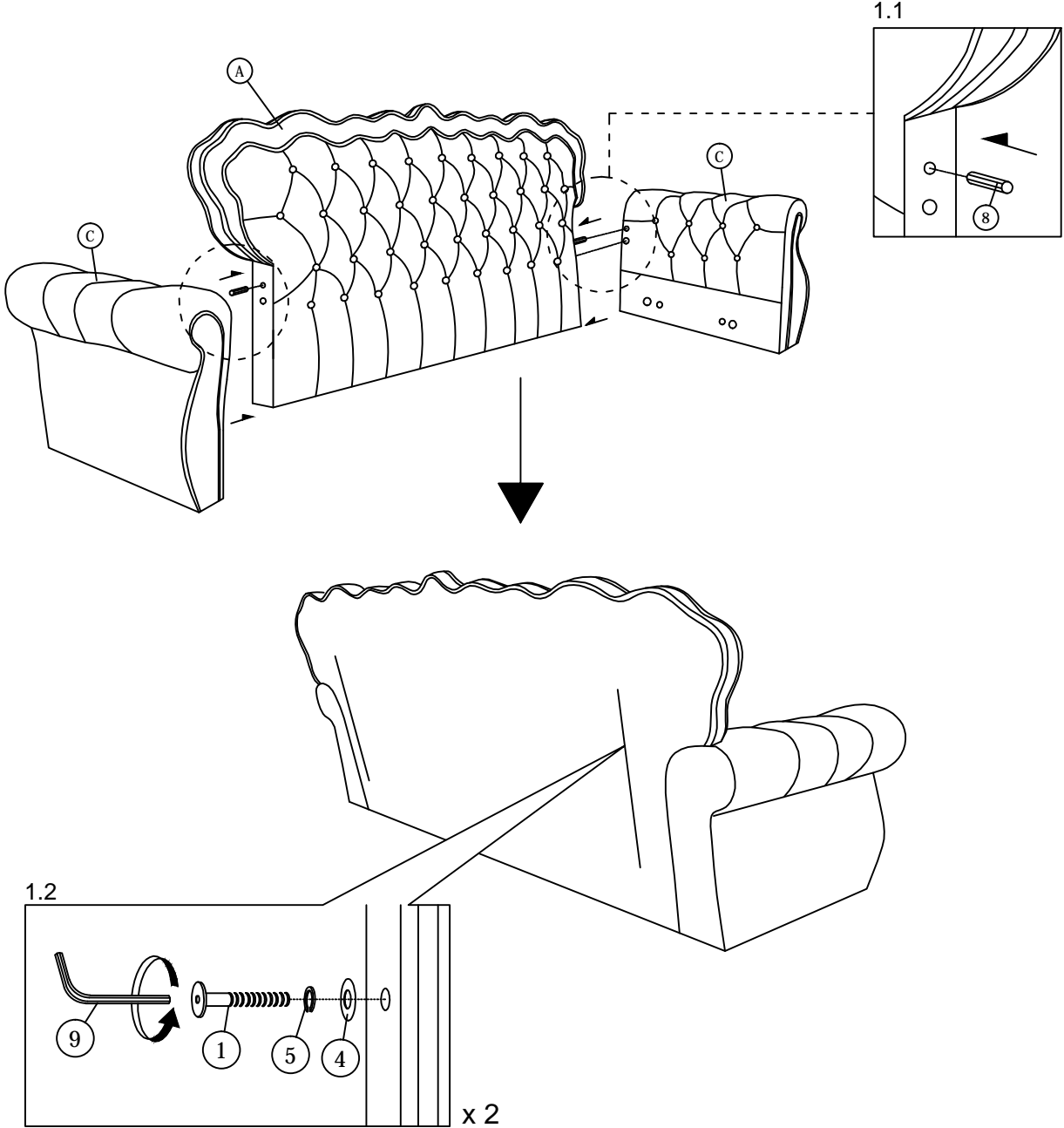

1. JCBC BOLT M6 x 70 x 2pcs	5. SPRING WASHER M6 x 2pcs	4. FLAT WASHER M6 x 2pcs	9. ALLEN KEY (BALL SHAPE) M4 x 1pc

8. WOOD DOWEL M10 x 30mm X 2PCS

TOOLS REQUIRED FOR ASSEMBLY

OR

Rubber Mallet Plastic Tip Hammer

EEI - 3373 SOFA

STEP 2

2.1 Fit the **Wood Dowel (8)** into the pre-drilled hole of the **Seat (B)** .

2.2 Insert and secure the **Seat (B)** to the **Back (A) & Arm (C)** using 7 piece of **JCBC Bolt (3)**, 7 piece of **Flat Washer (6)**, and 7 piece of **Spring Washer (7)**. Use **Allen Key (10)** to tighten. (Note : Finish step 2 : Please tighten bolt at step 1.2)

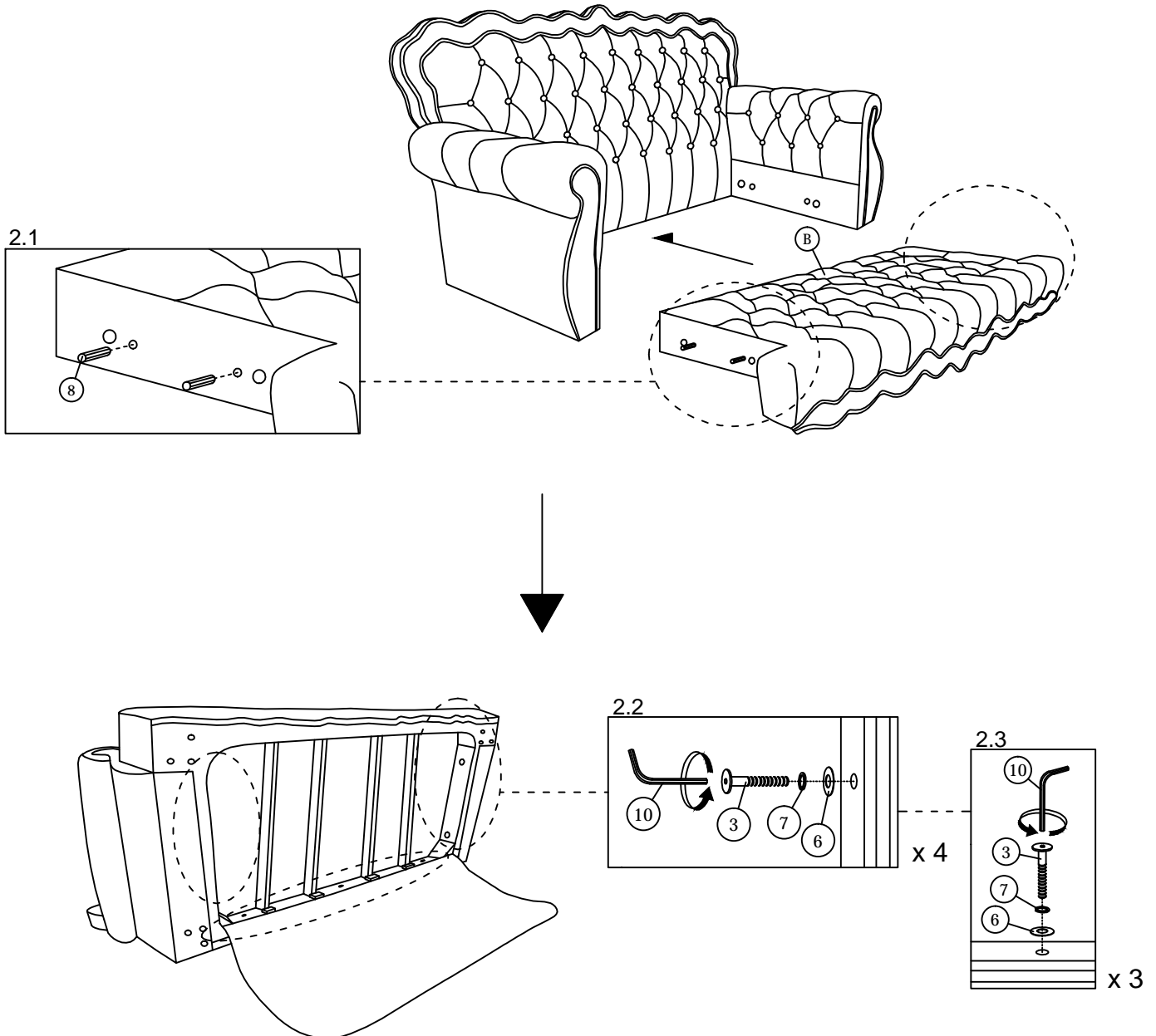

3. JCBC BOLT M6 x 70 x 7pcs	7. SPRING WASHER M6 x 7pcs	6. FLAT WASHER M6 x 7pcs	10. ALLEN KEY (BALL SHAPE) M4 x 1pc

8. WOOD DOWEL M10 x 30mm X 4PCS

TOOLS REQUIRED FOR ASSEMBLY

OR

Rubber Mallet Plastic Tip Hammer





EEI - 3373 SOFA

STEP 3

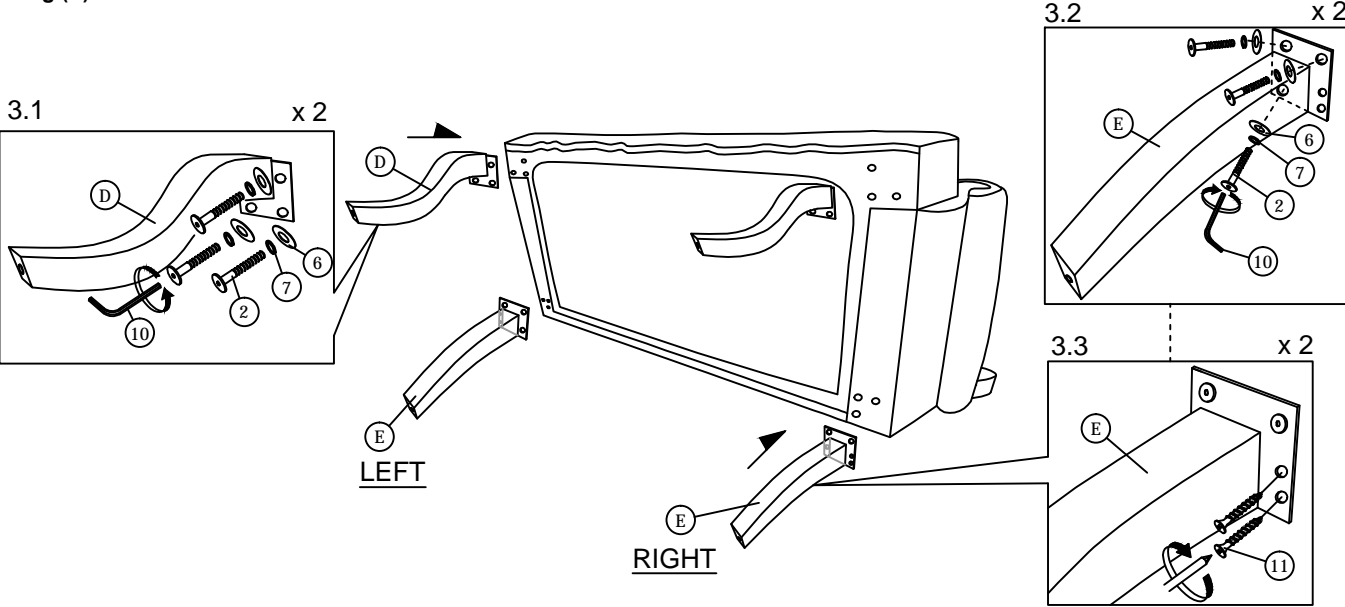
3.1 Insert and secure 1 piece of **Front Leg (D)** using 3 pieces of **JCBB Bolt (2)**, 3 pieces of **Flat Washer (6)** and 3 pieces of **Spring Washer (7)**. Use **Allen Key (10)** to tighten. Repeat steps for the other side of **Front Leg (D)**.

3.2 Insert and secure 1 piece of **Back Leg (E)** using 3 pieces of **JCBB Bolt (2)**, 3 pieces of **Flat Washer (6)** and 3 pieces of **Spring Washer (7)** and 2 pieces of **Wood Screw (11)**. Use **Allen Key (10)** and **Screwdriver** to tighten. Repeat steps for the other side of **Back Leg (E)**



			
2. JCBB BOLT M8 x 30 x 12pcs	7. SPRING WASHER M8 x 12pcs	6. FLAT WASHER M8 x 12pcs	10. ALLEN KEY (BALL SHAPE) M5 x 1pc



11. WOOD SCREW M4 x 32 x 4pcs

TOOLS REQUIRED FOR ASSEMBLY

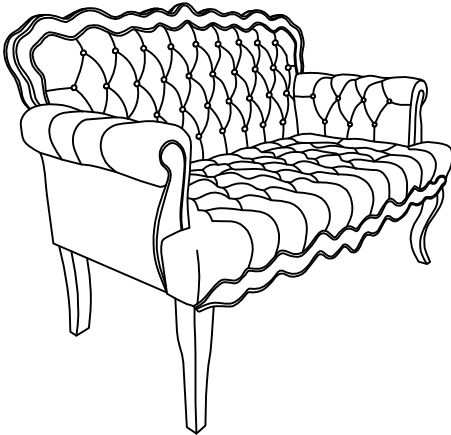

STEP 4

4.1 Carefully position the assembled Sofa to the desired location by four adults.



Assembly is complete. The Sofa is ready to use now!

NOTE: Hardware may loosen over time. Periodically check that all connections are tight.