

EEI-3578 BENCH

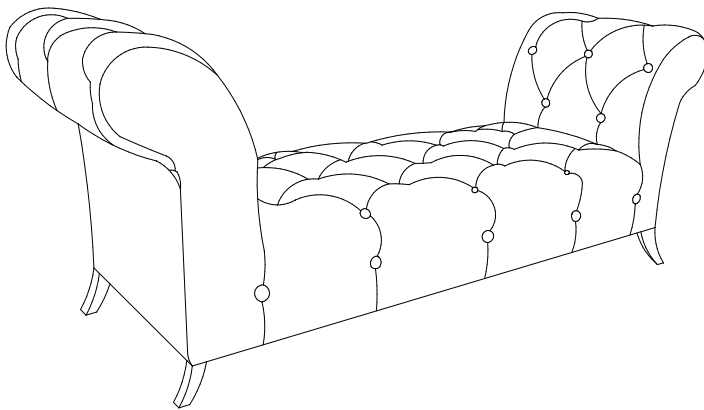

Thank you for purchasing the **MODWAY BENCH**.

Before you start, here are some helpful advice:

1. We suggest you spend a short time reading through this leaflet and then follow the simple step-by-step instructions.
2. Owing to the size and weight of the Bench, we recommend that it is assembled by two adults, on a carpeted or padded area, in the room that it is intended for. Approximate assembly time: 30 minutes.
3. Please do not use any tools other than those provided or recommended in these instructions.
4. Please do not throw away any of the packaging or the instruction until you have checked all the components and hardware and the furniture is fully assembled. Please ensure that the packaging is disposed of in a safe and environmentally friendly way.
5. Assemble all components loosely until advised to tighten. Depending on use, it may be necessary to tighten the components from time to time, so please save the tools that have been provided.
6. Please keep all pieces out of reach of children.



Hardware:

- A.  Bolt M8x60mm x8
- B.  Flat Washer x8
- C.  Allen Wrench M8 x1

Components:

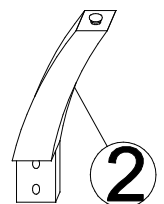
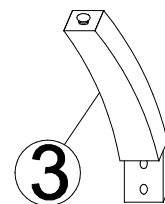
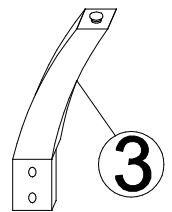
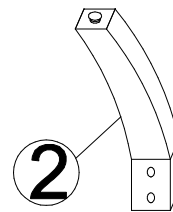
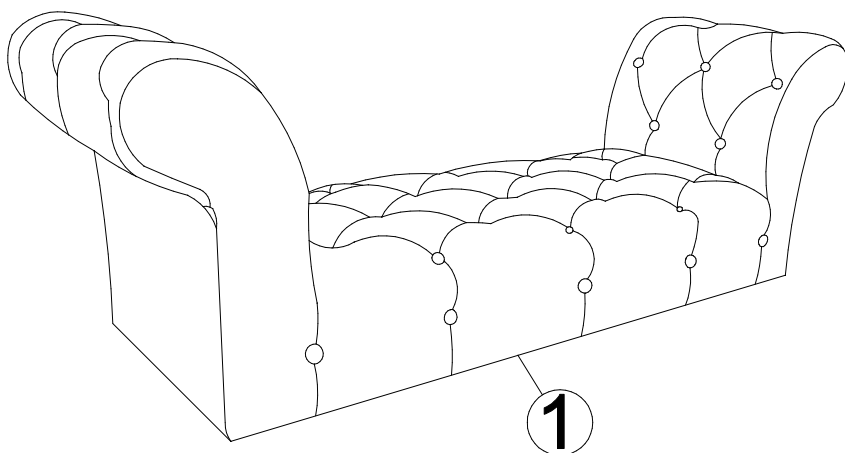

1. Bench Body x1

2. Leg #2 x2

3. Leg #3 x2

STEP 1:

1. Take out 2 pieces of **Legs #2 (2)**, 2 pieces of **Legs #3 (3)** and hardware package in the carton..
2. Please put **Bench Body (1)** upside down on a carpeted or padded surface by two adults.
Open the HOOK & LOOP on the either side at the bottom of the **Bench Body (1)**.

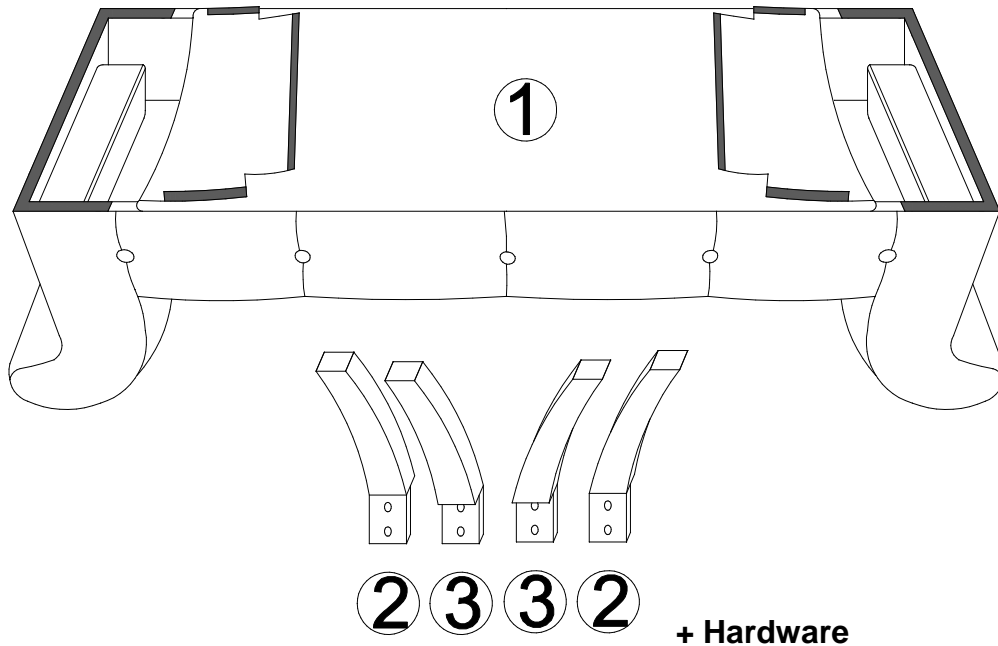

STEP 2:

1. Please note there are labels on the corners of the **Bench Body (1)** and each leg, please make sure the each leg match to the right location.
2. Attach 1 piece of **Leg #2 (2)** to the corner of the **Bench Body (1)** by using 2 pieces of **Bolts (A)** with 2 pieces of **Flat Washers (B)** as shown.
3. Use **Allen Wrench (C)** to tighten **Bolts (A)**. Don't fully tight **Bolts (A)**.
4. Repeat the same steps for the other 3 pieces of Legs as shown.
5. When all Legs are fixed, please fully tighten all **Bolts (A)**.

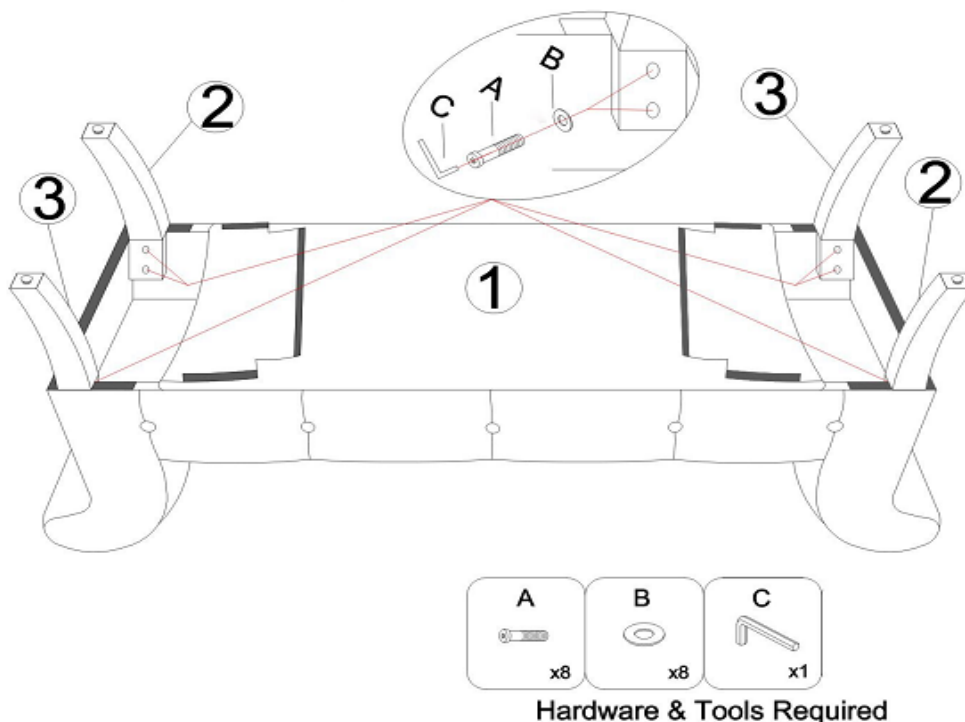

STEP 3:

1. Close the HOOK&LOOP on the bottom of the **Bench Body (1)**.
2. Carefully turn over the assembled Bench by two adults as shown to avoid leg crack.

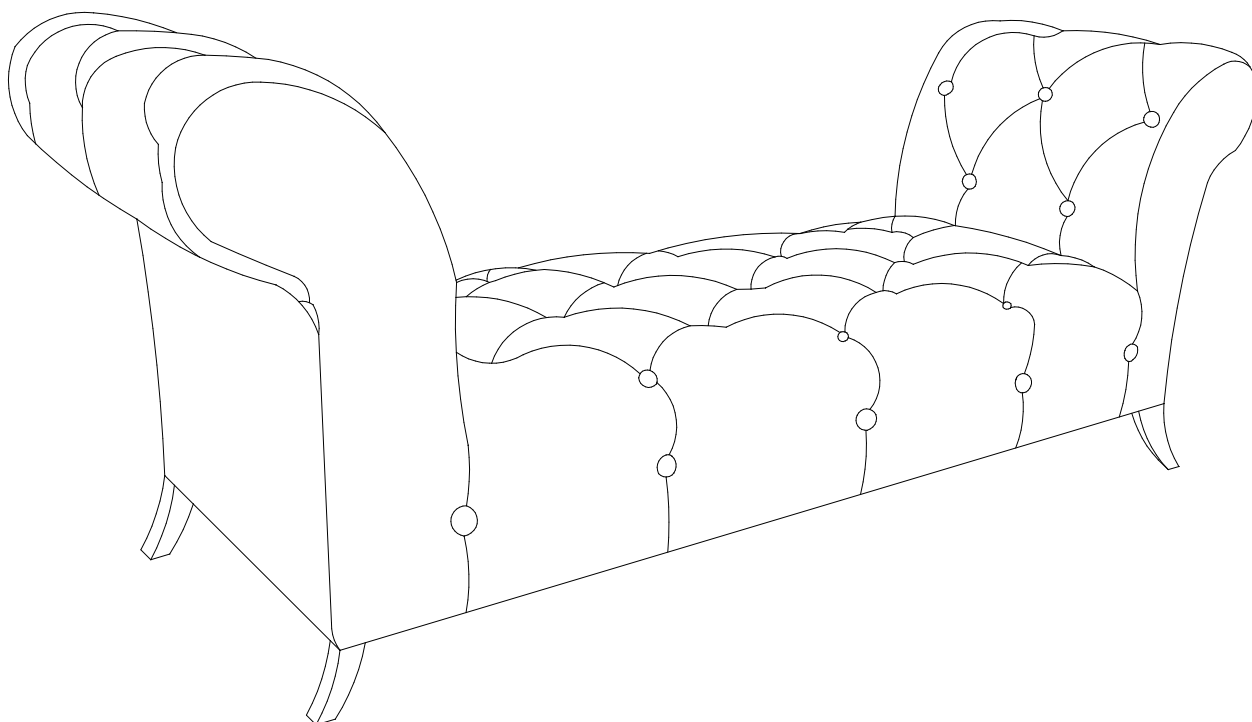
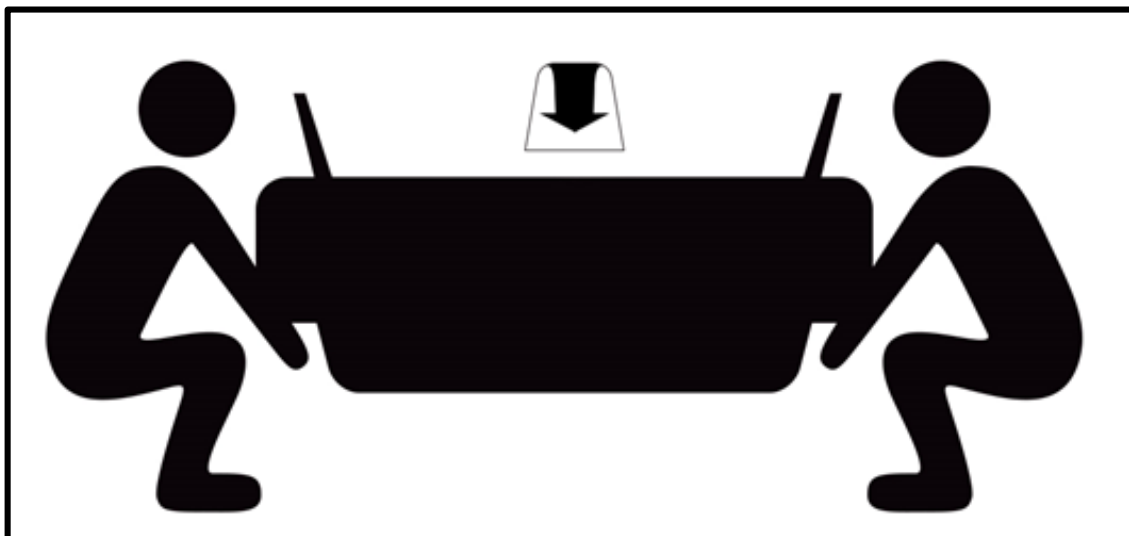

Assembly is complete. Your Bench is ready to enjoy now!